



 Read this manual carefully before operating this vehicle.

OWNER'S MANUAL

Star Venture

Star Venture TC

XV19FJ

LIT-11626-31-04

2DF-28199-10

EAU82390

WARNING

Operating, servicing and maintaining a passenger vehicle or off-road vehicle can expose you to chemicals including engine exhaust, carbon monoxide, phthalates, and lead, which are known to the State of California to cause cancer and birth defects or other reproductive harm. To minimize exposure, avoid breathing exhaust, do not idle the engine except as necessary, service your vehicle in a well-ventilated area and wear gloves or wash your hands frequently when servicing your vehicle. For more information go to www.P65Warnings.ca.gov/passenger-vehicle.

 **Read this manual carefully before operating this vehicle. This manual should stay with this vehicle if it is sold.**

Congratulations on your purchase of the Yamaha Star Venture and Star Venture TC. This model is the result of Yamaha's vast experience in the production of fine sporting, touring, and pacesetter racing machines. It represents the high-degree of craftsmanship and reliability that have made Yamaha a leader in these fields.

This manual will give you an understanding of the operation, inspection, and basic maintenance of this motorcycle. If you have any questions concerning the operation or maintenance of your motorcycle, please consult your local Yamaha dealer. The design and manufacture of this Yamaha motorcycle fully comply with the emissions standards for clean air applicable at the date of manufacture. Yamaha has met these standards without reducing the performance or economy of operation of the motorcycle. To maintain these high standards, it is important that you and your Yamaha dealer pay close attention to the recommended maintenance schedules and operating instructions contained within this manual.

Yamaha continually seeks advancements in product design and quality. Therefore, while this manual contains the most current product information available at the time of printing, there may be minor discrepancies between your motorcycle and this manual. If there is any question concerning this manual, please consult your Yamaha dealer.

TIP

The Infotainment System Owner's Manual must also be read for a complete understanding of the operation of this vehicle.

EWA10012





WARNING

Please read this manual and the "YOU AND YOUR MOTORCYCLE: RIDING TIPS" booklet carefully before operating this motorcycle. Do not attempt to operate this motorcycle until you have attained adequate knowledge of its controls and operating features. Regular inspections and careful maintenance, along with good operating techniques, will help ensure that you safely enjoy the capabilities and reliability of this motorcycle.

Important manual information

EAU10134

Particularly important information is distinguished in this manual by the following notations:

	This is the safety alert symbol. It is used to alert you to potential personal injury hazards. Obey all safety messages that follow this symbol to avoid possible injury or death.
	A WARNING indicates a hazardous situation which, if not avoided, could result in death or serious injury.
	A NOTICE indicates special precautions that must be taken to avoid damage to the vehicle or other property.
	A TIP provides key information to make procedures easier or clearer.

*Product and specifications are subject to change without notice.

Important manual information

EAU10194

**XV19FJ
OWNER'S MANUAL**
©2017 by Yamaha Motor Corporation, U.S.A.
1st edition, May 2017
All rights reserved.
Any reprinting or unauthorized use
without the written permission of
Yamaha Motor Corporation, U.S.A.
is expressly prohibited.
Printed in Japan.
P/N LIT-11626-31-04

Table of contents

Location of important labels	1-1	D-mode (drive mode)	6-9	For your safety – pre-operation checks	7-1
Safety information	2-1	Clutch lever	6-10	Operation and important riding points	8-1
Description	3-1	Shift pedal	6-10	Starting the engine	8-1
Left view	3-1	Brake lever	6-11	Shifting	8-2
Right view	3-2	Brake pedal	6-11	Engine break-in	8-4
Controls and instruments	3-3	Brake system	6-12	Parking	8-4
Smart key system	4-1	Traction control system	6-13	Periodic maintenance and adjustment	9-1
Smart key system	4-1	Fuel tank cap	6-14	Owner's tool kit	9-2
Part 15 of FCC Rules	4-2	Fuel	6-15	Periodic maintenance chart for the emission control system	9-3
Operating range of the smart key... ..	4-3	Fuel tank overflow hose	6-16	General maintenance and lubrication chart	9-5
Handling of the smart key and mechanical keys	4-3	Catalytic converters	6-17	Removing and installing the cowling and panels	9-9
Smart key	4-5	Seat	6-17	Checking the spark plugs	9-11
Replacing the smart key battery	4-6	Seat heater switch (passenger)	6-19	Canister	9-12
Main switch	4-7	Helmet holder	6-19	Engine oil and oil filter cartridge	9-13
Compartment access	4-10	Storage compartments	6-20	Replacing the air filter element	9-16
Special features	5-1	Windshield	6-22	Checking the engine idling speed	9-17
SURE-PARK	5-1	Rear view mirrors	6-22	Valve clearance	9-17
Infotainment system	5-2	Saddlebags and Tour trunk	6-23	Tires	9-17
Cruise control system	5-3	Adjustable wind deflector	6-25	Cast wheels	9-19
Alarm system (Venture TC)	5-6	Leg air vents	6-25	Clutch lever	9-20
Instrument and control functions	6-1	Adjustable footrests	6-25	Checking the brake lever free play	9-21
Handlebar switches	6-1	Adjusting the shock absorber assembly	6-26		
Indicator lights and warning lights	6-3	Auxiliary DC jack	6-27		
Speedometer and Tachometer	6-6	Headset jacks	6-28		
		Talk button (passenger)	6-28		
		Audio controls (passenger)	6-28		
		Sidestand	6-29		
		Ignition circuit cut-off system	6-29		

Table of contents

Brake light switches	9-21	Storage	10-4
Checking the front and rear brake pads	9-22	Specifications	11-1
Checking the brake fluid level	9-23	Consumer information	12-1
Changing the brake and clutch fluids	9-24	Identification numbers	12-1
Drive belt slack	9-24	Diagnostic connector	12-2
Checking and lubricating the throttle grip	9-25	Vehicle data recording	12-2
Checking and lubricating the brake and shift pedals	9-25	Reporting safety defects	12-3
Checking and lubricating the brake and clutch levers	9-26	Motorcycle noise regulation	12-4
Checking and lubricating the sidestand	9-27	Maintenance record	12-5
Lubricating the rear suspension	9-27	YAMAHA MOTOR CORPORATION, U.S.A. 2015 AND LATER MODEL STREET & DUAL-PURPOSE MOTORCYCLE LIMITED WARRANTY	12-7
Lubricating the swingarm pivots	9-27	YAMAHA EXTENDED SERVICE (Y.E.S.)	12-9
Checking the front fork	9-28	Index	13-1
Checking the steering	9-28		
Checking the wheel bearings	9-29		
Battery	9-29		
Replacing the fuses	9-30		
Vehicle lights	9-33		
Supporting the motorcycle	9-33		
Troubleshooting	9-34		
Troubleshooting chart	9-35		
Emergency mode	9-36		
Motorcycle care and storage	10-1		
Matte color caution	10-1		
Care	10-1		

Location of important labels

EAU10385

1 Read and understand all of the labels on your vehicle. They contain important information for safe and proper operation of your vehicle. Never remove any labels from your vehicle. If a label becomes difficult to read or comes off, a replacement label is available from your Yamaha dealer.

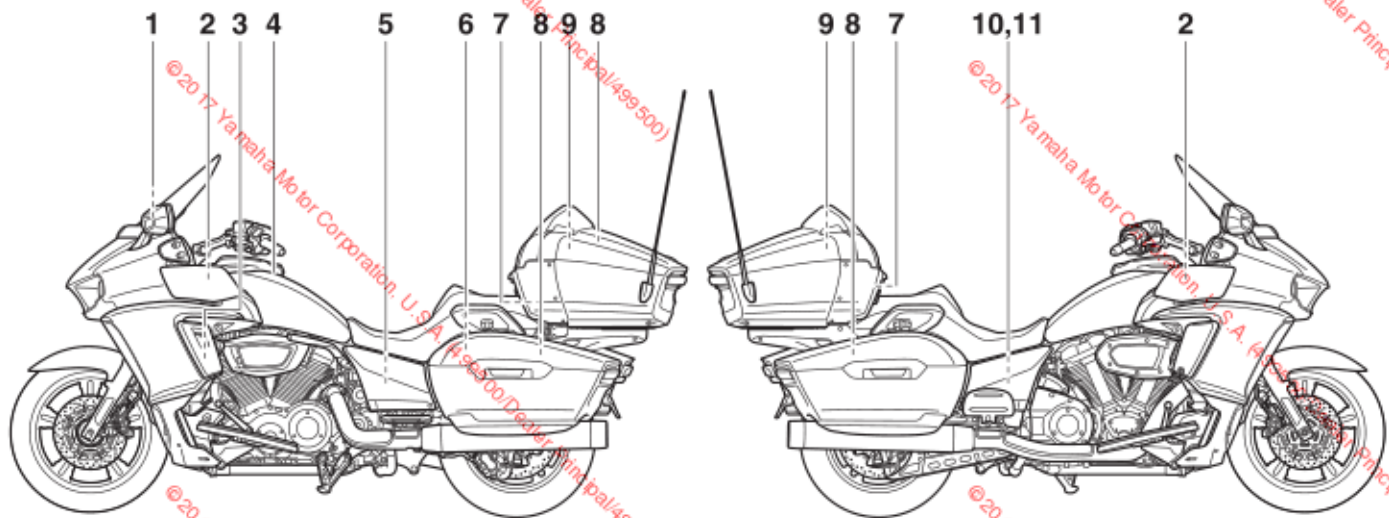

Location of important labels

1

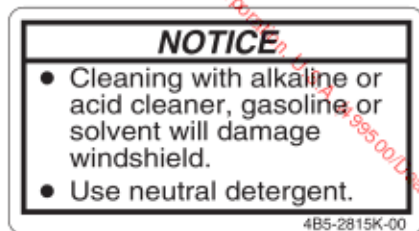

3

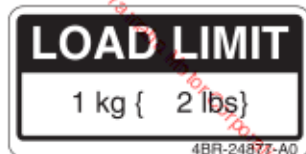

5



2



4

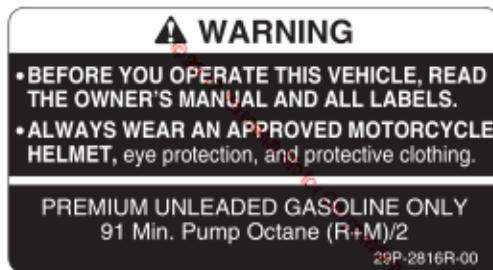

6

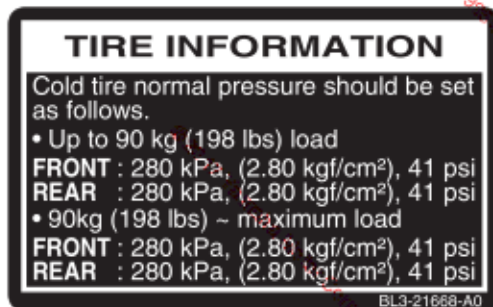

Location of important labels

1

7 Venture TC



9

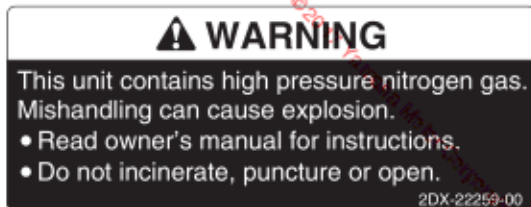

10

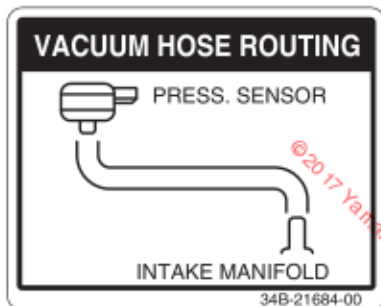

8

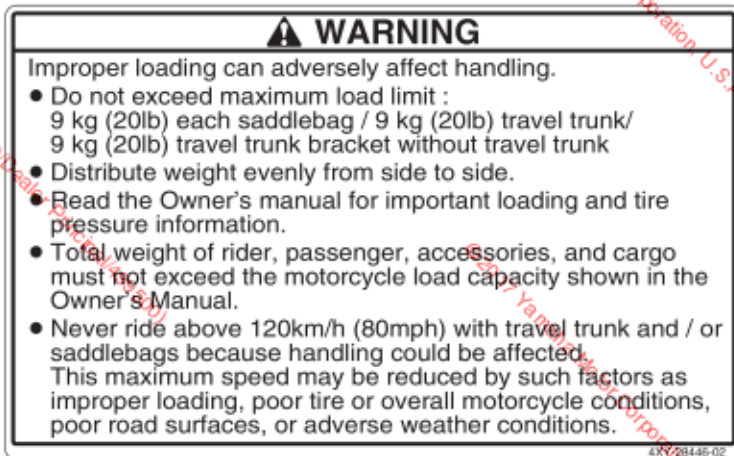

11

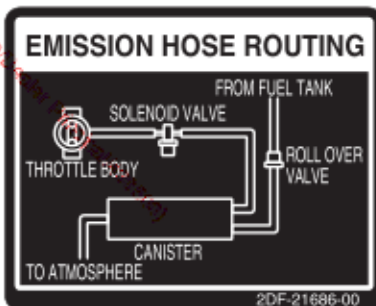

EAU1028C

Be a Responsible Owner

As the vehicle's owner, you are responsible for the safe and proper operation of your motorcycle.

Motorcycles are single-track vehicles. Their safe use and operation are dependent upon the use of proper riding techniques as well as the expertise of the operator. Every operator should know the following requirements before riding this motorcycle.

He or she should:

- Obtain thorough instructions from a competent source on all aspects of motorcycle operation.
- Observe the warnings and maintenance requirements in this Owner's Manual.
- Obtain qualified training in safe and proper riding techniques.
- Obtain professional technical service as indicated in this Owner's Manual and/or when made necessary by mechanical conditions.

- Never operate a motorcycle without proper training or instruction. Take a training course. Beginners should receive training from a certified instructor. Contact an authorized motorcycle dealer to find out about the training courses nearest you.

Safe Riding

Perform the pre-operation checks each time you use the vehicle to make sure it is in safe operating condition. Failure to inspect or maintain the vehicle properly increases the possibility of an accident or equipment damage. See page 7-1 for a list of pre-operation checks.

- This motorcycle is designed to carry the operator and a passenger.
- The failure of motorists to detect and recognize motorcycles in traffic is the predominating cause of automobile/motorcycle accidents. Many accidents have been caused by an automobile driver who did not see the motorcycle. Making yourself conspicuous ap-

pears to be very effective in reducing the chance of this type of accident.

Therefore:

- Wear a brightly colored jacket.
- Use extra caution when you are approaching and passing through intersections, since intersections are the most likely places for motorcycle accidents to occur.
- Ride where other motorists can see you. Avoid riding in another motorist's blind spot.
- Never maintain a motorcycle without proper knowledge. Contact an authorized motorcycle dealer to inform you on basic motorcycle maintenance. Certain maintenance can only be carried out by certified staff.

Safety information

- Many accidents involve inexperienced operators. In fact, many operators who have been involved in accidents do not even have a current motorcycle license.
- Make sure that you are qualified and that you only lend your motorcycle to other qualified operators.
- Know your skills and limits. Staying within your limits may help you to avoid an accident.
- We recommend that you practice riding your motorcycle where there is no traffic until you have become thoroughly familiar with the motorcycle and all of its controls.
- Many accidents have been caused by error of the motorcycle operator. A typical error made by the operator is veering wide on a turn due to excessive speed or undercornering (insufficient lean angle for the speed).
- Always obey the speed limit and never travel faster than warranted by road and traffic conditions.
- Always signal before turning or changing lanes. Make sure that other motorists can see you.
- The posture of the operator and passenger is important for proper control.
- The operator should keep both hands on the handlebar and both feet on the operator footrests during operation to maintain control of the motorcycle.
- The passenger should always hold onto the operator, the seat strap or grab bar, if equipped, with both hands and keep both feet on the passenger footrests. Never carry a passenger unless he or she can firmly place both feet on the passenger footrests.
- Never ride under the influence of alcohol or other drugs.
- This motorcycle is designed for on-road use only. It is not suitable for off-road use.

Protective Apparel

The majority of fatalities from motorcycle accidents are the result of head injuries. The use of a safety helmet is the single most critical factor in the prevention or reduction of head injuries.

- Always wear an approved helmet.
- Wear a face shield or goggles. Wind in your unprotected eyes could contribute to an impairment of vision that could delay seeing a hazard.
- The use of a jacket, heavy boots, trousers, gloves, etc., is effective in preventing or reducing abrasions or lacerations.
- Never wear loose-fitting clothes, otherwise they could catch on the control levers, footrests, or wheels and cause injury or an accident.
- Always wear protective clothing that covers your legs, ankles, and feet. The engine or exhaust system become very hot during or after operation and can cause burns.
- A passenger should also observe the above precautions.



Safety information

Avoid Carbon Monoxide Poisoning

All engine exhaust contains carbon monoxide, a deadly gas. Breathing carbon monoxide can cause headaches, dizziness, drowsiness, nausea, confusion, and eventually death.

Carbon Monoxide is a colorless, odorless, tasteless gas which may be present even if you do not see or smell any engine exhaust. Deadly levels of carbon monoxide can collect rapidly and you can quickly be overcome and unable to save yourself. Also, deadly levels of carbon monoxide can linger for hours or days in enclosed or poorly ventilated areas. If you experience any symptoms of carbon monoxide poisoning, leave the area immediately, get fresh air, and SEEK MEDICAL TREATMENT.

- Do not run engine indoors. Even if you try to ventilate engine exhaust with fans or open windows and doors, carbon monoxide can rapidly reach dangerous levels.
- Do not run engine in poorly ventilated or partially enclosed areas such as barns, garages, or carports.

- Do not run engine outdoors where engine exhaust can be drawn into a building through openings such as windows and doors.

Loading

Adding accessories or cargo to your motorcycle can adversely affect stability and handling if the weight distribution of the motorcycle is changed. To avoid the possibility of an accident, use extreme caution when adding cargo or accessories to your motorcycle. Use extra care when riding a motorcycle that has added cargo or accessories. Here, along with the information about accessories below, are some general guidelines to follow if loading cargo to your motorcycle:

The total weight of the operator, passenger, accessories and cargo must not exceed the maximum load limit.

Operation of an overloaded vehicle could cause an accident.

Maximum load:

185 kg (408 lb) (Venture TC)
188 kg (414 lb) (Venture)

When loading within this weight limit, keep the following in mind:

- Cargo and accessory weight should be kept as low and close to the motorcycle as possible. Securely pack your heaviest items as close to the center of the vehicle as possible and make sure to distribute the weight as evenly as possible on both sides of the motorcycle to minimize imbalance or instability.
- Shifting weights can create a sudden imbalance. Make sure that accessories and cargo are securely attached to the motorcycle before riding. Check accessory mounts and cargo restraints frequently.
- Properly adjust the suspension for your load (suspension-adjustable models only), and check the condition and pressure of your tires.
- Never attach any large or heavy items to the handlebar, front fork, or front fender. These items, including such cargo as sleeping bags, duffel bags, or

Safety information

tents, can create unstable handling or a slow steering response.

- **This vehicle is not designed to pull a trailer or to be attached to a sidecar.**

Genuine Yamaha Accessories

Choosing accessories for your vehicle is an important decision. Genuine Yamaha accessories, which are available only from a Yamaha dealer, have been designed, tested, and approved by Yamaha for use on your vehicle.

Many companies with no connection to Yamaha manufacture parts and accessories or offer other modifications for Yamaha vehicles. Yamaha is not in a position to test the products that these aftermarket companies produce. Therefore, Yamaha can neither endorse nor recommend the use of accessories not sold by Yamaha or modifications not specifically recommended by Yamaha, even if sold and installed by a Yamaha dealer.

Aftermarket Parts, Accessories, and Modifications

While you may find aftermarket products similar in design and quality to genuine Yamaha accessories, recognize that some aftermarket accessories or modifications are not suitable because of potential safety hazards to you or others. Installing aftermarket products or having other modifications performed to your vehicle that change any of the vehicle's design or operation characteristics can put you and others at greater risk of serious injury or death. You are responsible for injuries related to changes in the vehicle.

Keep the following guidelines in mind, as well as those provided under "Loading" when mounting accessories.

- Never install accessories or carry cargo that would impair the performance of your motorcycle. Carefully inspect the accessory before using it to make sure that it does not in any way reduce ground clearance or cornering clearance, limit suspension travel,

steering travel or control operation, or obscure lights or reflectors.

- Accessories fitted to the handlebar or the front fork area can create instability due to improper weight distribution or aerodynamic changes. If accessories are added to the handlebar or front fork area, they must be as lightweight as possible and should be kept to a minimum.
- Bulky or large accessories may seriously affect the stability of the motorcycle due to aerodynamic effects. Wind may attempt to lift the motorcycle, or the motorcycle may become unstable in cross winds. These accessories may also cause instability when passing or being passed by large vehicles.
- Certain accessories can displace the operator from his or her normal riding position. This improper position limits the freedom of movement of the

operator and may limit control ability, therefore, such accessories are not recommended.

- Use caution when adding electrical accessories. If electrical accessories exceed the capacity of the motorcycle's electrical system, an electric failure could result, which could cause a dangerous loss of lights or engine power.

Aftermarket Tires and Rims

The tires and rims that came with your motorcycle were designed to match the performance capabilities and to provide the best combination of handling, braking, and comfort. Other tires, rims, sizes, and combinations may not be appropriate. See page 9-17 for tire specifications and for information on servicing and replacing your tires.

Transporting the Motorcycle

Be sure to observe following instructions before transporting the motorcycle in another vehicle.

- Remove all loose items from the motorcycle.
- Check that the fuel cock (if equipped) is in the off position and that there are no fuel leaks.
- Shift the transmission into gear (for models with a manual transmission).
- Secure the motorcycle with tie-downs or suitable straps that are attached to solid parts of the motorcycle, such as the frame or upper front fork triple clamp (and not, for example, to rubber-mounted handlebars or turn signals, or parts that could break). Choose the location for the straps carefully so the straps will not rub against painted surfaces during transport.
- The suspension should be compressed somewhat by the tie-downs, if possible, so that the motorcycle will not bounce excessively during transport.

Description

EAU10411

Left view

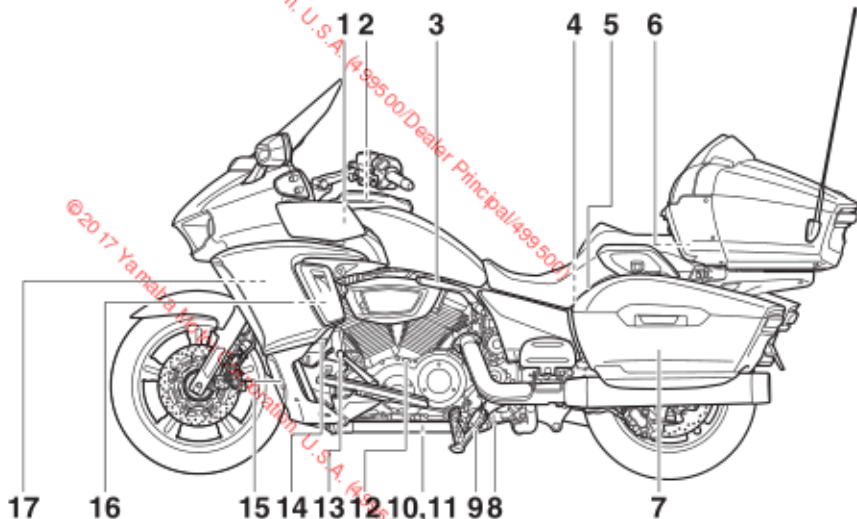

1. Storage compartment B (page 6-20)
2. Fuel tank cap (page 6-14)
3. SURE-PARK lever (page 5-11)
4. Engine oil filler cap (page 9-13)
5. Engine oil dipstick (page 9-13)
6. Storage compartment D (Venture TC) (page 6-20)
7. Saddlebag (page 6-23)
8. Engine oil drain bolt (oil tank) (page 9-13)
9. Sidestand (page 6-29)
10. Engine oil drain bolt A (crankcase) (page 9-13)
11. Engine oil drain bolt B (crankcase) (page 9-13)
12. Crankcase filler bolt (page 9-13)
13. Shift pedal (page 6-10)
14. Leg air vent lever (page 6-25)
15. Fog lamp (Venture TC) (page 9-33)
16. Storage compartment A (page 6-20)
17. Fuses (page 9-30)

Right view

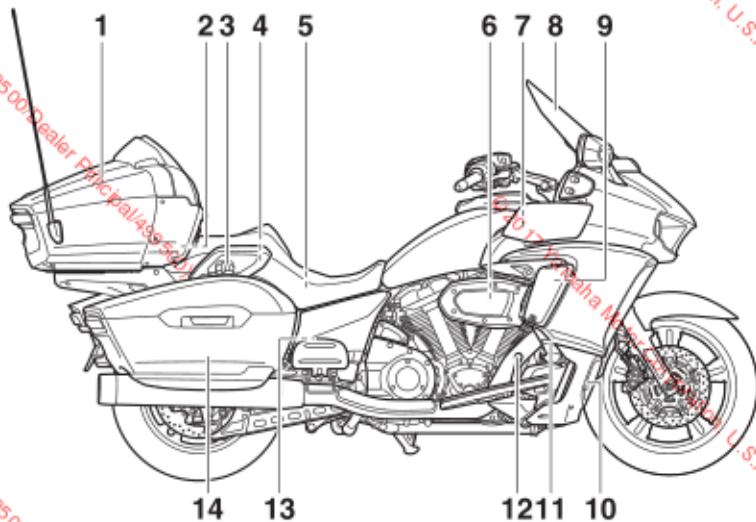

1. Tour trunk (page 6-23)

2. Storage compartment E (Venture TC) (page 6-20)

3. Seat heater switch (passenger) (page 6-19)

4. Fuses (page 9-30)

5. Battery (page 9-29)

6. Air filter element (page 9-16)

7. Storage compartment C (page 6-20)

8. Windshield (page 6-22)

9. Rear brake fluid reservoir (page 9-23)

10. Fog lamp (Venture TC) (page 9-33)

11. Leg air vent lever (page 6-25)

12. Brake pedal (page 6-11)

13. Rear shock absorber adjuster (page 6-26)

14. Saddlebag (page 6-23)

Description

EAU10431

Controls and instruments

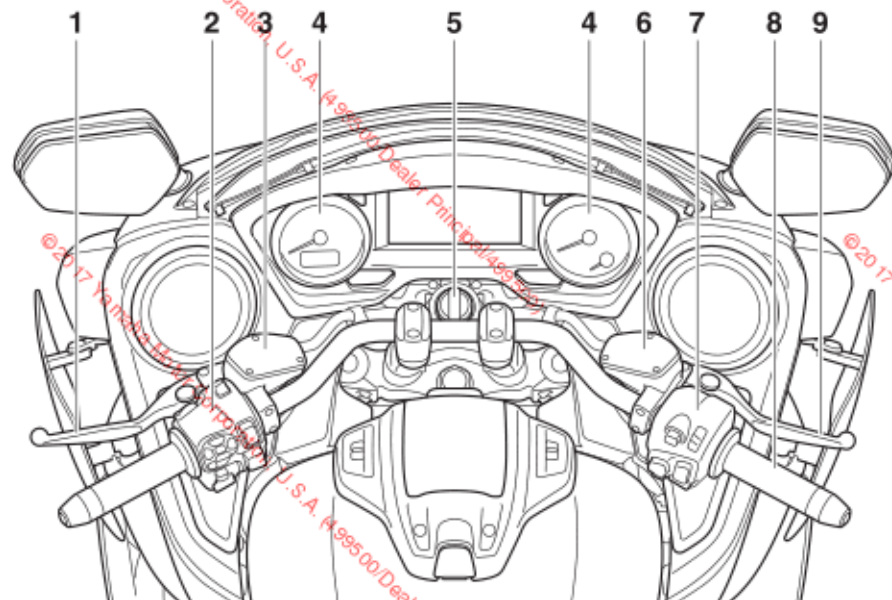

1. Clutch lever (page 6-10)

2. Left handlebar switches (page 6-1)

3. Clutch fluid reservoir (page 9-23)

4. Speedometer and Tachometer (page 6-6)

5. Main switch (page 4-7)

6. Front brake fluid reservoir (page 9-23)

7. Right handlebar switches (page 6-1)

8. Throttle grip

9. Brake lever (page 6-11)

Smart key system

The smart key system enables you to operate and lock the vehicle without using a mechanical key. In addition, there is an answer-back function to help you locate the vehicle in a parking lot. (See page 4-5.)

The smart key system consists of the internally mounted antenna, the smart key and its lock and unlock buttons, the smart key system indicator light, the main switch, and the lock "🔒" and unlock "🔓" switches.

EAU81000

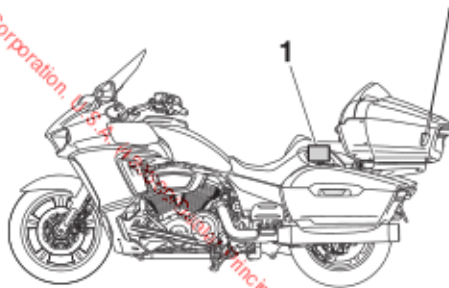

1. Vehicle mounted antenna

EWA14704

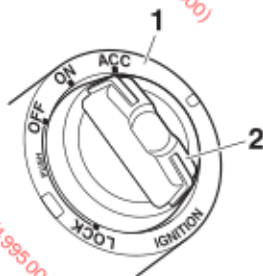

1. Main switch
2. Main switch knob



1. Smart key system indicator light "🔑"

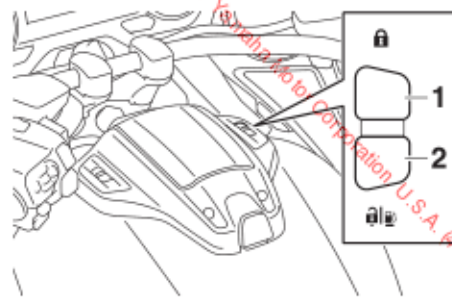

1. Lock switch "🔒"
2. Unlock switch "🔓"

⚠️ WARNING

- Keep implanted pacemakers or cardiac defibrillators, as well as other electric medical devices away from the vehicle mounted antenna (see illustration).
- Radio waves transmitted by the antenna may affect the operation of such devices when close by.
- If you have an electric medical device, consult a doctor or the device manufacturer before using this vehicle.

Smart key system

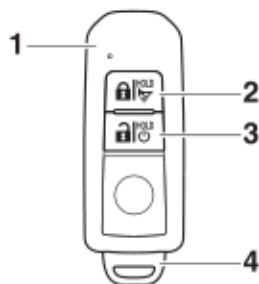

1. Smart key
2. Lock button "LOCK"
3. Unlock button "UNLOCK"
4. Mechanical key

TIP

To preserve vehicle battery power, the smart key system turns off approximately 9 days after the vehicle was last used (the answer-back function is disabled). In this situation, simply push the main switch knob to turn the smart key system back on.

NOTICE

The smart key system uses weak radio waves. The smart key system may not work in the following situations.

- The smart key is placed in a location exposed to strong radio waves or other electromagnetic noise
- There are facilities nearby that are emitting strong radio waves (TV or radio towers, power plants, broadcasting stations, airports, etc.)
- You are carrying or using communication equipment such as radios or mobile phones in close proximity of the smart key
- The smart key is in contact with or covered by a metallic object
- Other vehicles equipped with a smart key system are nearby

In such situations, move the smart key to another location and perform the operation again. If it still does not work, operate the vehicle in emergency mode. (See page 9-36.)

Part 15 of FCC Rules

This device complies with Part 15 of FCC Rules. Operation is subject to the following two conditions:

- (1) this device may not cause interference, and
- (2) this device must accept any interference, including interference that may cause undesired operation of this device.

FCC WARNING

Changes or modifications not expressly approved by the party responsible for compliance could void the user's authority to operate the equipment.

Operating range of the smart key

The vehicle will recognize the smart key from a range of about 80 cm (31.5 in) from the rider's seat, excluding the storage compartments, saddlebags or tour trunk.

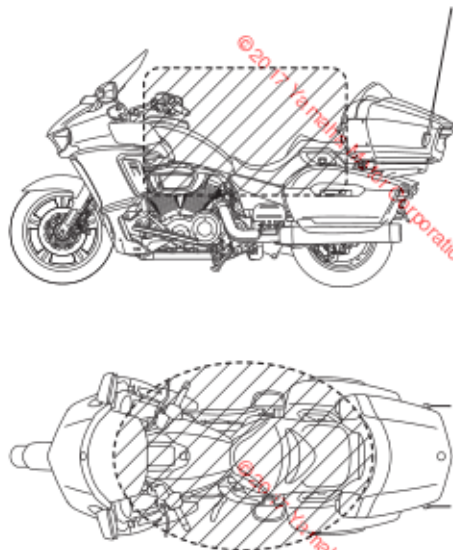

TIP

- As the smart key system uses weak radio waves, the operating range may be affected by the surrounding environment.
- When the smart key battery is low, the system may not work or its operating range become small.

Handling of the smart key and mechanical keys

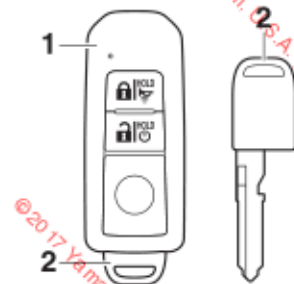

1. Smart key
2. Mechanical key

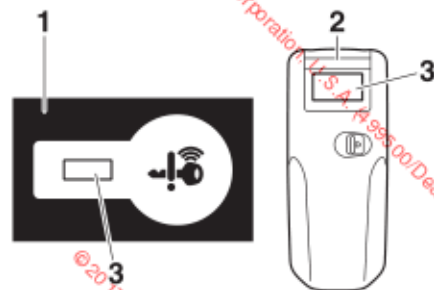

1. Identification number card
2. Smart key
3. Identification number

Smart key system

EWA17952

WARNING

- The smart key should be carried with you. Do not store it on the vehicle.
- When the smart key is within operating range, exercise due care because other people not carrying the smart key can start the engine and operate the vehicle.

About the keys

Included with the vehicle is one smart key with a built-in mechanical key, a spare mechanical key, and one identification number card. The smart key system identification number can also be found on the inside of the smart key itself.

In case of vehicle trouble, the mechanical key can be used to open the saddlebags (or tour trunk) and you can remove your personal effects.

In case of smart key trouble, the identification number and a mechanical key can be used to start the vehicle in emergency mode. (See page 9-36.)

If the smart key is lost and the smart key system identification number is unknown, the entire smart key system will need to be replaced at considerable cost.

TIP

- You can register up to six smart keys for the vehicle. See a Yamaha dealer regarding spare smart keys.
- If a smart key is lost, contact a Yamaha dealer immediately to prevent the vehicle from being stolen.
- Smart key battery life is approximately two years.
- If the smart key continually receives radio waves, the battery will discharge quickly. Turn off when not in use and keep away from televisions, radios, and computers, etc.
- Replace the smart key battery soon if the “” indicator light flashes for 20 seconds when the vehicle is first turned on. (See page 4-6.)

ECA21573

NOTICE

The smart key has precision electronic components. Observe the following precautions to prevent possible malfunction or damage.

- Do not place or store the smart key in a storage compartment. The smart key may be damaged from road vibrations or excessive heat.
- Do not drop, bend, or subject the smart key to strong impacts.
- Do not submerge the smart key in water or other liquids.
- Do not place heavy items or excessive stress on the smart key.
- Do not leave the smart key in a place exposed to direct sunlight, high temperature or high humidity.
- Do not grind or attempt to modify the smart key.
- Keep the smart key away from strong magnetic fields and magnetic objects such as key holders, TVs, and computers.
- Keep the smart key away from electric medical equipment.

EAU81630

- Do not allow oils, polishing agents, fuel, or any strong chemicals to come in contact with the smart key. The smart key body may become discolored or cracked.

Smart key

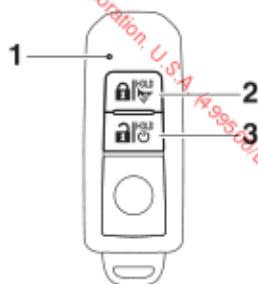

1. Smart key indicator light
2. Lock button "🔒"
3. Unlock button "🔓"

In normal operation, the smart key indicator light will come on briefly whenever a smart key button is pushed.

To turn the smart key on or off

Push the unlock button "🔓" for 1 second to turn the smart key on or off. When the smart key is turned off, the vehicle cannot be operated even if the smart key is within operating range. To operate the vehicle, turn the smart key on and bring it within operating range.

Remote answer-back function

Push the lock button "🔒" for 1 second to operate the answer-back function remotely. The horn will sound twice and all of the turn signal lights will flash. This feature is convenient for locating your vehicle in a parking lot or other crowded areas.

To use the mechanical key

On the back of the smart key, slide the lock button and pull out the mechanical key.

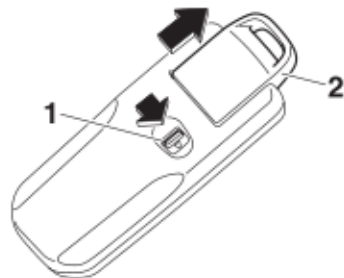

1. Lock button
2. Mechanical key

After using the mechanical key, insert it back into the smart key until the lock button clicks.

Smart key system

EAUJ81640

ECA24010

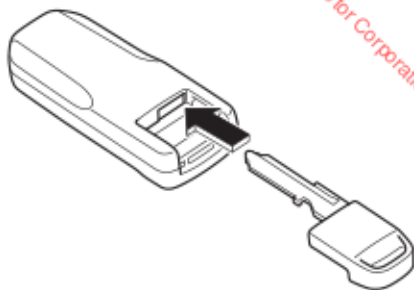

Replacing the smart key battery

If the smart key system indicator light flashes for about 20 seconds when the power of the vehicle is turned on, replace the battery.



1. Smart key system indicator light "43"

EWA14724

WARNING

- The battery and other removable parts may cause injury if swallowed. Keep the battery and other removable parts away from children.
- Do not expose the battery to direct sunlight or other heat sources.

NOTICE

- Do not apply excessive force to the smart key when replacing the battery.
- Do not use a screwdriver or other hard object to force open the key.
- Take precautions to prevent the waterproof seal from being damaged or contaminated by dirt.
- Do not touch the internal circuits and terminals. This may cause malfunctions.
- Make sure the battery is installed correctly. Confirm the direction of the positive/"+" side of the battery.

To replace the smart key battery

1. Gently pry open the smart key case.



- Remove the battery cover and O-ring.

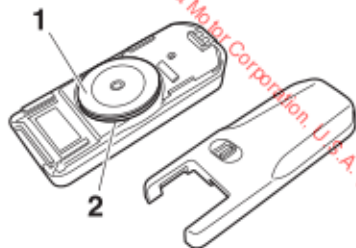

- Battery cover
- O-ring

- Remove the battery.

TIP

Dispose of the removed battery in accordance with local regulations.

- Install a new battery as shown. Note the polarity of the battery.

Specified battery:
CR2025

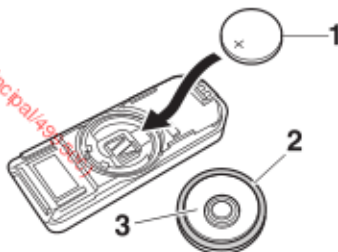

- Battery
- O-ring
- Battery cover

- Install the O-ring and battery cover.
- Gently snap the smart key case closed.

Main switch

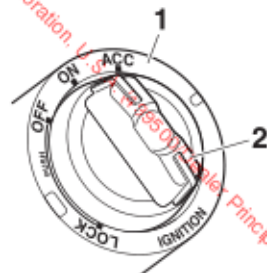

- Main switch
- Main switch knob

The main switch is used to turn the vehicle power on and off, lock and unlock the steering, and can be set to the accessory position.

With the smart key turned on and in operating range, push and release the main switch knob. Then, within 5 seconds, turn the main switch to the desired position.

TIP

- If the smart key is turned off, the vehicle will not recognize the smart key even if it is within operating range.

Smart key system

- If the main switch or the lock “

EW490360

WARNING

Never operate the main switch while the vehicle is moving. Doing so would result in loss of electrical power and possible loss of control or an accident.

ON

1



1. Push.
2. Turn.

All electrical circuits are supplied with power, and the engine can be started.

TIP

The main switch does not automatically turn off, even if the smart key is turned off. Be sure to turn the main switch to “OFF” or “LOCK” before leaving the vehicle.

EAU81660

OFF

2



1. Turn.

All electrical systems are off. If the smart key is then also turned off or out of range, neither the main switch nor the lock and unlock switches can be operated.

TIP

If the smart key cannot be confirmed when the main switch is turned to “OFF”, the beeper will sound for 3 seconds and the indicator light “-S” will flash for 30 seconds.

- During this 30 seconds, the main switch can be operated without the smart key.
- After 30 seconds, the vehicle power will turn off automatically.

EAU81670

- To turn the vehicle power off immediately, push the main switch knob four times within 2 seconds.

TIP

If the steering will not lock, try turning the handlebar back to the right slightly.

LOCK

EAU81680

To unlock the steering

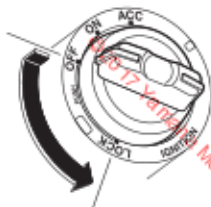

1. Push and turn.

The steering is locked and all electrical systems are off.

To lock the steering

1. Turn the handlebar all the way to the left.
2. With the smart key on and in operating range, push and turn the main switch to "LOCK".



1. Push and turn.

With the smart key on and in operating range, push and turn the main switch to the desired position.

ACC

1



1. Push.
2. Turn.

The hazard lights and the infotainment system can be used, but all other electrical systems are off.

TIP

- If the main switch is turned to "ACC" but the smart key cannot be confirmed (the smart key is outside operating range or has been turned off or lost), the beeper will sound for 3 seconds and the smart key system indicator light will flash for 30 seconds.
- During this 30 seconds, the main switch can be operated.

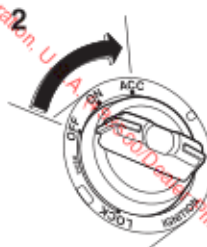

Smart key system

- After 30 seconds, the vehicle power will turn off automatically.

ECA25990

NOTICE

If you must use the hazard lights or infotainment system for an extended length of time, start the engine to prevent battery discharge.

Compartment access

The fuel tank cap lid, storage compartment C, and the saddlebag and tour trunk can be electronically unlocked.

Fuel tank access

1. With the main switch set to "OFF", push the unlock switch "🔓" for 1 second to unlock the fuel tank cap lid.

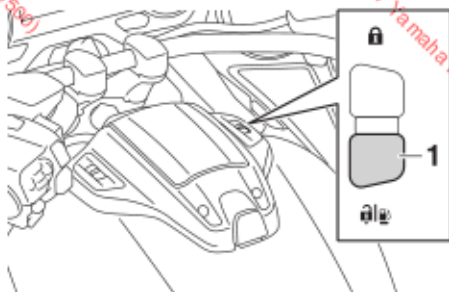

1. Unlock switch "🔓"

EAU81701

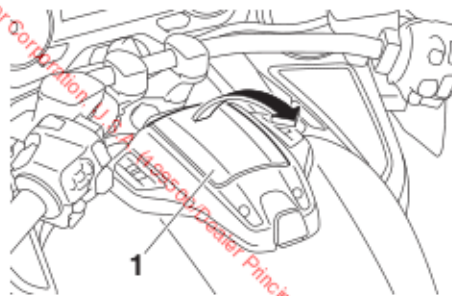

1. Fuel tank cap lid

2. When finished refueling, simply push the lid back to its original position.

Storage compartments

Storage compartment C

1. Push the unlock button "🔓" or the unlock switch "🔓". Upon authentication of the smart key, the beeper will sound twice and the turn signal lights will flash twice.

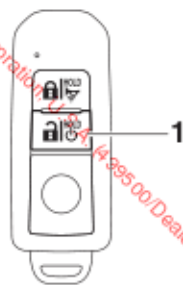

1. Unlock button "🔓"

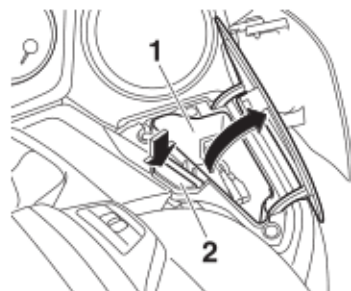

1. Storage compartment C
2. Storage compartment button

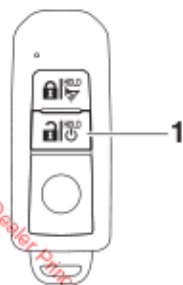

1. Lock button "🔒"

3. When finished, close the lid and then push the lock button "🔒" or the lock switch "🔒". The beeper will sound once and the turn signal lights will flash once.

Saddlebag or Tour trunk

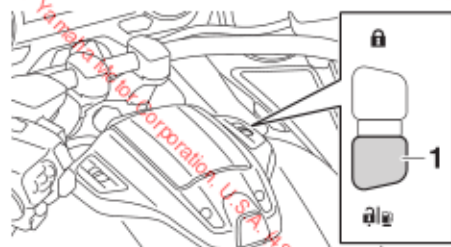

1. Unlock switch "🔓"

2. Push the storage compartment button to open.

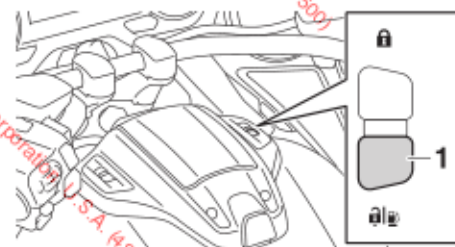

1. Unlock switch "🔓"

2. Push down on the lock cylinder.

Smart key system

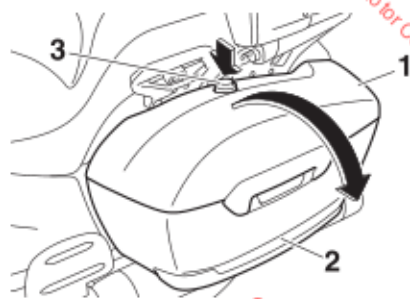

1. Saddlebag lid
2. Saddlebag
3. Saddlebag lock



1. Tour trunk lid
2. Tour trunk
3. Tour trunk lock

TIP

- If the lock cylinders were locked with the mechanical key, they cannot be electronically unlocked.
- Occasionally, it may be necessary to reset the lock cylinders to their proper unlock position with the mechanical key.

3. When finished, close the lid and then push down on the lid.

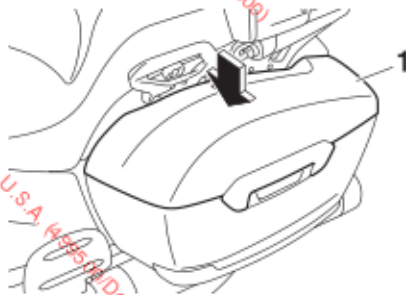

1. Saddlebag lid

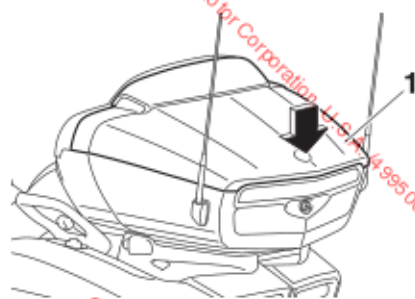

1. Tour trunk lid

TIP

A false click may be heard when a lid is first closed. Be sure to press down on the lid afterwards to make sure it securely latches.

4. Push the lock button "🔒" or the lock switch "🔒". The beeper will sound once and the turn signal lights will flash once.



- Storage compartment C: 0.5 kg (1 lb)
- Tour trunk: 9.0 kg (20 lb)
- Total vehicle: 185 kg (408 lb) (Venture TC)
188 kg (414 lb) (Venture)

1. Lock button "🔒"

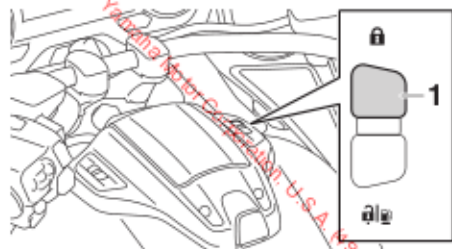

1. Lock switch "🔒"

EWA20370

⚠️ WARNING

Do not exceed the following maximum loads:

- Left saddlebag: 9.0 kg (20 lb)
- Right saddlebag: 9.0 kg (20 lb)

Special features

SURE-PARK

SURE-PARK is a parking-assist feature designed to be used on smooth, level ground. SURE-PARK allows you to move the vehicle forward or backward via electric motors at a slow, controlled speed.

⚠ WARNING

Never lower the SURE-PARK lever while riding.

To avoid loss of balance and possible injury; never operate SURE-PARK if not straddling the vehicle, have the passenger disembark before using SURE-PARK.

To use SURE-PARK

1. With the engine running, sidestand up and the vehicle stopped, shift the transmission to neutral.
2. Double-check the surrounding area for people and obstructions, then lower the SURE-PARK lever.

EAU81741

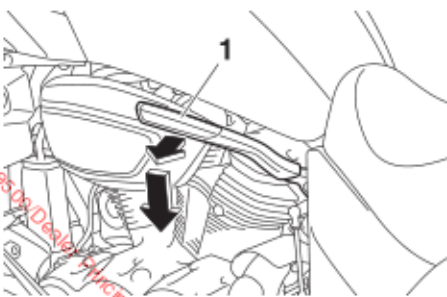

1. SURE-PARK lever

3. The neutral position indicator light will go off, and the SURE-PARK indicator light will come on.

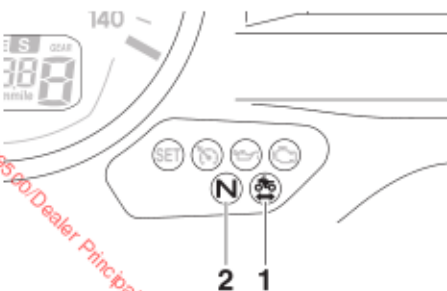

1. SURE-PARK indicator light "🏍"
2. Neutral indicator light "N"

4. To move backward, push the "RVS" side of the SURE-PARK switch. To move forward, push the "FWD" side of the SURE-PARK switch.

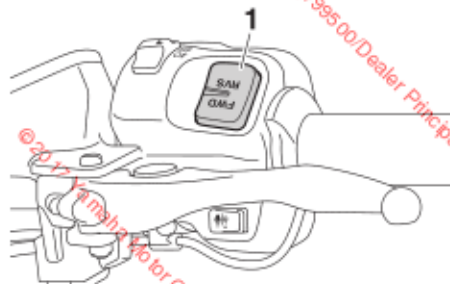

1. SURE-PARK switch "FWD/RVS"

5. When finished, return the SURE-PARK lever to its upright position.
6. The SURE-PARK indicator light will go off, and the neutral indicator light will come on.
7. Lower the sidestand and turn the main switch off, or shift the transmission into gear and ride away.

Notes on usage

SURE-PARK can be used for a total of 50 seconds at one time.

ECA26110

NOTICE

- “Finish parking soon” message will appear about 10 seconds prior.
- “SURE-PARK self-protection engaged” will appear after that. The system will be unavailable for about 5 minutes.
- “SURE-PARK cannot be used” will appear when the “RVS” or “FWD” switch is pushed and the sidestand is down or other condition for using SURE-PARK is not met.

The SURE-PARK motors will stop if a wheel hits an obstacle or if SURE-PARK is used on too steep an incline or decline. In this case, return the SURE-PARK lever to its upright position or turn the main switch off to reset the system.

When the SURE-PARK lever is lowered, a mechanical lock system will prevent gear changes. When riding, if gear changes become rough or difficult, have a Yamaha dealer inspect the SURE-PARK lever and lock mechanism.

- Do not use on cobblestone roads or other non-smooth surfaces.
- Do not coast downhill with SURE-PARK engaged.
- Do not use SURE-PARK to park “in gear”.
- Do not use the “FWD” or “RVS” switches to change direction without first stopping the vehicle’s momentum.

Infotainment system

EWA01752



1. Touchscreen

This model is equipped with audio, communication, and navigation functions (Venture TC), which are controlled by the infotainment system. The system is operated via the center display (touchscreen) and various controls found on the handlebar or passenger area.

EWA20490

⚠ WARNING

Always stop the vehicle before operating the touchscreen.
Never take your hands off the handlebars while riding.

Special features

Always concentrate on riding by keeping your eyes and mind on the road.

Notes on usage

In addition to the audio, communication, and navigation features, certain vehicle controls and vehicle-related information are also integrated into the system. The infotainment system can control or adjust the following:

- audio system
- intercom
- phone (via bluetooth)
- CB radio (Venture TC)
- navigation system (Venture TC)
- seat heaters
- grip warmer
- windshield height

TIP

- Available functions vary by model and equipped accessories.
- Read the Infotainment System Owner's Manual.

Cruise control system

EAUJ81760

This model is equipped with a cruise control system designed to maintain a set cruising speed.

The cruise control system operates in 3rd gear and above, and at speeds between about 50 km/h (31 mph) and 160 km/h (100 mph).

EWA16341

WARNING

- **Improper use of the cruise control system may result in loss of control, which could lead to an accident. Do not activate the cruise control system in heavy traffic, poor weather conditions, or among winding, slippery, hilly, rough or gravel roads.**
- **When traveling uphill or downhill, the cruise control system may not be able to maintain the set cruising speed.**
- **To prevent accidentally activating the cruise control system, turn it off when not in use. Make sure that the cruise control system indicator light “**

1. Cruise control power switch “

1. Cruise control setting indicator light “SET”
2. Cruise control system indicator light “

5-3

Activating and setting the cruise control system

1. Push the cruise control power switch "CC". The cruise control system indicator light "SET" will come on.

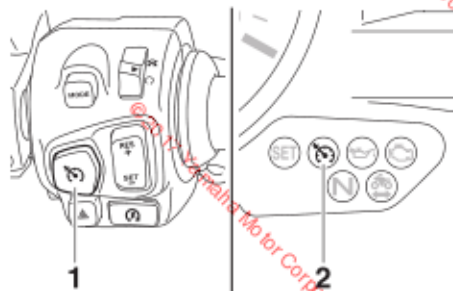

1. Cruise control power switch "CC"
2. Cruise control system indicator light "SET"

2. Push the "SET-" side of the cruise control setting switch to activate the cruise control system. Your current traveling speed will become the set cruising speed. The cruise control setting indicator light "SET" will come on.

Adjusting the set cruising speed

While the cruise control system is operating, push the "RES+" side of the cruise control setting switch to increase the set cruising speed or the "SET-" side to decrease the set speed.

TIP

Pushing the setting switch once will change the speed in increments of approximately 2.0 km/h (1.2 mph). Holding the "RES+" or "SET-" side of the cruise control setting switch down will increase or decrease the speed continuously until the switch is released.

You can also manually increase your traveling speed using the throttle. After you have accelerated, you can set a new cruising speed by pushing the "SET-" side of the setting switch. If you do not set a new cruising speed, when you return the throttle grip, the vehicle will decelerate to the previously set cruising speed.

Deactivating the cruise control system

Perform one of the following operations to cancel the set cruising speed. The "SET" indicator light will go off.

- Turn the throttle grip past the closed position in the deceleration direction.

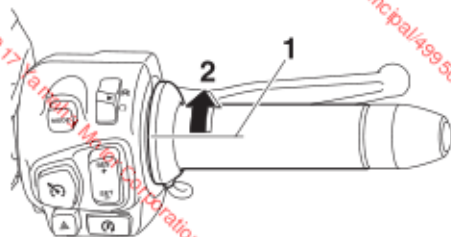

1. Closed position
2. Cruise control cancel direction

- Apply the front or rear brake.
- Disengage the clutch.

Push the power switch to turn off the cruise control system. The "SET" indicator light and the "SET" indicator light will go off.

Special features

TIP

Traveling speed decreases as soon as the cruise control system is deactivated; unless the throttle grip is turned.

Using the resume function

Push the "RES+" side of the cruise control setting switch to reactivate the cruise control system. The traveling speed will return to the previously set cruising speed. The "SET" indicator light will come on.

EWA16351

WARNING

It is dangerous to use the resume function when the previously set cruising speed is too high for current conditions.

TIP

Pushing the power switch while the system is operating will turn the system off completely and erase the previously set cruising speed. You will not be able to use the resume function until a new cruising speed has been set.

Automatic deactivation of the cruise control system

The cruise control system for this model is electronically controlled and is linked with the other control systems. The cruise control system will automatically become deactivated under the following conditions:

- The cruise control system is not able to maintain the set cruising speed.
- Wheel slip or wheel spin is detected. (If the traction control system has not been turned off, the traction control system will work.)
- The engine stop switch is set to the "X" position.
- The engine stalls.
- The sidestand is lowered.

When traveling with a set cruising speed, if the cruise control system is deactivated under the above conditions, the "C" indicator light will go off and the "SET" indicator light will flash for 4 seconds, and then go off.

When not traveling with a set cruising speed, if the engine stop switch is set to the "X" position, the engine stalls,

or the sidestand is lowered, then the "C" indicator light will go off (the "SET" indicator light will not flash).

If the cruise control system is automatically deactivated, please stop and confirm that your vehicle is in good operating condition.

Before using the cruise control system again, activate it using the power switch.

TIP

In some cases, the cruise control system may not be able to maintain the set cruising speed when the vehicle is traveling uphill or downhill.

- When the vehicle is traveling uphill, the actual traveling speed may become lower than the set cruising speed. If this occurs, accelerate to the desired traveling speed using the throttle.
- When the vehicle is traveling downhill, the actual traveling speed may become higher than the set cruising speed. If this occurs, the setting switch cannot be used to adjust the set cruising speed. To reduce the traveling

speed, apply the brakes. When the brakes are applied, the cruise control system will become deactivated.

Self-diagnosis device

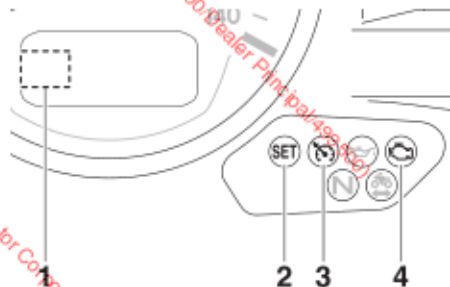

1. Error code display
2. Cruise control setting indicator light "SET"
3. Cruise control system indicator light "CC"
4. Engine trouble warning light "E" (with engine icon)

The cruise control system will also become deactivated when an irregularity with any of the vehicle systems is detected. The "SET" indicator light will go off and the "CC" indicator light will flash. You will not be able to use the cruise control system while the engine

trouble warning light is on, or while the cruise control system is malfunctioning.

NOTICE

If the display indicates an error code, the vehicle should be checked as soon as possible in order to avoid engine damage.

WARNING

If the cruise control system is not working correctly, the "CC" indicator light will flash. If this occurs, turn the cruise control system off and have a Yamaha dealer check it.

Alarm system (Venture TC)

When the main switch is turned to "OFF" or "LOCK", the alarm will automatically set after 1 minute of non-use. The alarm indicator light "A" will change from on (constantly lit) to a steady flashing.

To stop the alarm, make sure the smart key is turned on, and then simply push the main switch knob. The alarm indicator light will change from flashing (alarm set) to on (alarm deactivated). Also, when the fuel tank cap lid is opened to refuel the vehicle, the alarm indicator light will flash 10 times, the beeper will sound 2 times, and the alarm will automatically deactivate.

Adjusting the alarm sensitivity

1. Turn the main switch to "OFF" and push the unlock switch "U" for 1 second.
2. Wait 10 seconds for the beeper to sound twice.
3. After the beeper sounds, turn the main switch to "ON" and then to "OFF" within 3 seconds. The

Special features

alarm indicator light will flash and the beeper will sound to indicate the current setting.

- One beep: Standard
 - Two beeps: Sensitive
 - Three beeps: Dull
4. Repeat step 3 within 1 minute to change the alarm sensitivity setting in the following order:
Standard (one beep) → Sensitive (two beeps) → Dull (three beeps) → Standard (one beep)
 5. Once the desired setting has been made, turn the main switch to "ON" and wait 3 seconds. The alarm indicator light will come on.
 6. Finally, turn the main switch to "OFF". The alarm indicator light will flash twice. Setting is complete.
 7. Close the fuel tank cap lid.

Handlebar switches

EAU68055

Left

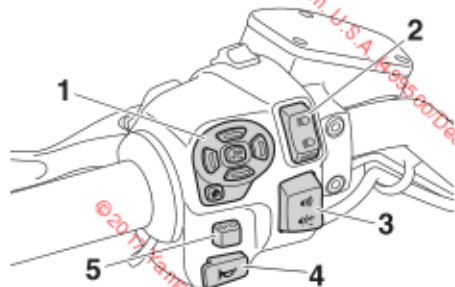

1. Navigation controls
2. Dimmer/Pass switch "HID/ PASS"
3. Volume switch "Speaker icon"
4. Horn switch "Horn icon"
5. Turn signal switch "Left/Right arrow icon"

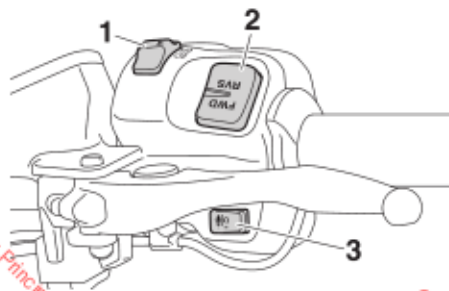

1. Fog lamp switch "FWD/OFF" (Venture TC)
2. SURE-PARK switch "FWD/RVS"
3. Talk button (rider) "Rider icon"

Right

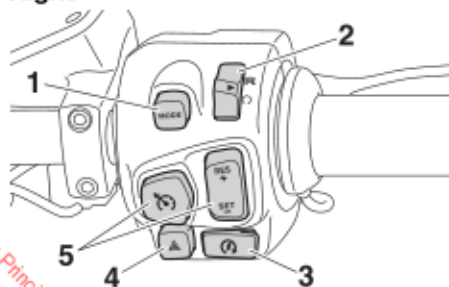

1. Drive mode switch "MODE"
2. Engine stop switch "Power symbol / Crossed-out power symbol"
3. Start switch "Power symbol"
4. Hazard switch "Triangle icon"
5. Cruise control switches

Dimmer/Pass switch "HID/ PASS"

EAU73021

Set this switch to "HID" for the high beam and to "PASS" for the low beam. To flash the high beam, push the pass side "PASS" of the switch while the headlights are on low beam.

Turn signal switch "Left/Right"

EAU81771

To signal a right-hand turn, push this switch to "Right". To signal a left-hand turn, push this switch to "Left". When released, the switch returns to the center position.

Since this model is equipped with a self-canceling system, the turn signal lights will self-cancel after the vehicle has traveled both about 150 m (490 ft) and for approximately 15 seconds. However, the turn signal lights can also be canceled manually by pushing the switch in after it has returned to the center position.

Horn switch "Horn icon"



EAU68030

Press this switch to sound the horn.

Instrument and control functions

Engine stop switch “/”

EAU81780

During normal operation, set this switch to “” (run). In case of emergency, set this switch to “” (stop) to stop the engine.

Start switch “”

EAU79890

Push this switch to crank the engine with the starter.

See page 8-1 for starting instructions prior to starting the engine.

The engine trouble warning light will come on while the start switch is pushed, but this does not indicate a malfunction.

Hazard switch “”

EAU81811

With the main switch in the “ON” or “ACC” position, use this switch to turn on the hazard lights (simultaneous flashing of all turn signal lights).

The hazard lights are used in case of an emergency or to warn other drivers when your vehicle is stopped where it might be a traffic hazard.

NOTICE

Do not use the hazard lights for an extended length of time with the engine not running, otherwise the battery may discharge.

Cruise control switches

See page 5-3 for an explanation of the cruise control system.

Drive mode switch “MODE”

See page 6-9 for an explanation of the drive mode.

Fog lamp switch “/OFF” (Venture TC)

Set the fog lamp switch to “” to turn on the fog lamps when the engine is running.

SURE-PARK switch “FWD/RVS”

See page 5-1 for an explanation of the SURE-PARK function.

Navigation controls

Use the navigation controls to select and set highlighted items. You can also use the navigation controls to return to the HOME screen.

See the infotainment system owner's manual for more information.

Volume switch “/”

Use this switch to adjust the volume or mute the sound.

See the infotainment system owner's manual for more information.

Talk button (rider) “”

Use this button to talk to the passenger or communicate using CB radio (Venture TC).

See the infotainment system owner's manual for more information.

Indicator lights and warning lights

EAU4939D

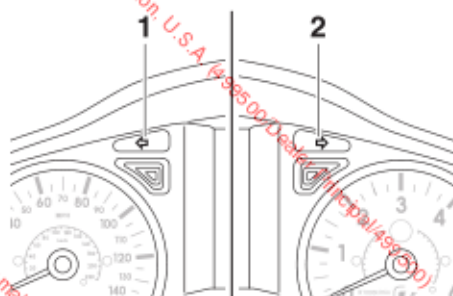

1. Left turn signal indicator light "↶"
2. Right turn signal indicator light "↷"

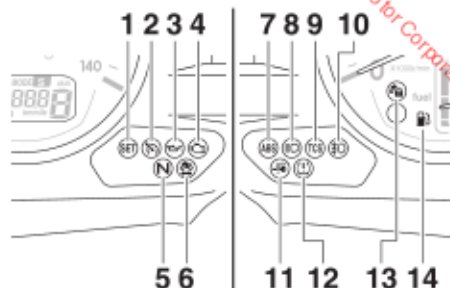

1. Cruise control setting indicator light "SET"
2. Cruise control system indicator light "Ⓢ"
3. Oil pressure warning light "⚠"
4. Engine trouble warning light "⚠"
5. Neutral indicator light "N"
6. SURE-PARK indicator light "Ⓢ"
7. ABS warning light "ABS"
8. High beam indicator light "Ⓢ"
9. Traction control system indicator light "TCS"
10. Fog lamp indicator light "Ⓢ" (Venture TC)
11. Smart key system indicator light "Ⓢ"
12. Tire pressure warning light "Ⓢ"
13. Alarm indicator light "Ⓢ" (Venture TC)
14. Fuel level warning light "Ⓢ"

Turn signal indicator lights "↶" and "↷"

EAU11032

Each indicator light will flash when its corresponding turn signal lights are flashing.

Neutral indicator light "N"

EAU11061

This indicator light comes on when the transmission is in the neutral position.

High beam indicator light "Ⓢ"

EAU11081

This indicator light comes on when the high beam of the headlight is switched on.

Fog lamp indicator light "Ⓢ" (Venture TC)

EAU8188D

This indicator light comes on when the fog lamps are turned on.

SURE-PARK indicator light "Ⓢ"

EAU81891

This light comes on when SURE-PARK is engaged. This light will flash when an operation or conditional error has occurred.

TIP

When the vehicle is turned on, this light should come on for a few seconds and then go off. Otherwise, have a Yamaha dealer check the vehicle.

Instrument and control functions

Oil pressure warning light

EAU82240

This warning light comes on if the engine oil pressure is low.

The electrical circuit of the warning light can be checked by turning the main switch to "ON". The warning light should come on and remain on until the engine is started.

If the warning light does not come on initially when the main switch is turned to "ON", have a Yamaha dealer check the electrical circuit.

NOTICE

ECA21210

If the warning light comes on when the engine is running, stop the engine immediately and check oil level. If the oil level is below the minimum level, add sufficient oil of the recommended type to raise it up to the correct level. If the oil pressure warning light remains on even if the oil level is correct, immediately turn the engine off and have a Yamaha dealer check the vehicle.

TIP

If the warning light does not go off after starting the engine, check the engine oil level and add oil if necessary. (See page 9-13.)

If the warning light remains on after adding engine oil, have a Yamaha dealer check the vehicle.

Fuel level warning light

EAU81900

This warning light comes on when you are low on fuel. When the fuel level drops below approximately 3.6 L (0.95 US gal, 0.79 Imp.gal), the light will come on to remind you to refuel as soon as possible.

When the main switch is turned to "ON", the light will perform a circuit check (come on for a few seconds and then go off).

If the warning light does not come on during the circuit check, or if the warning light remains on after refueling, have a Yamaha dealer check the vehicle.

TIP

This model is equipped with a self-diagnosis device for the fuel level detection circuit. If a malfunction is detected, the fuel level warning light will flash repeatedly. Have a Yamaha dealer check the vehicle.

Cruise control indicator lights /"SET"

These indicator lights come on when the cruise control system is activated. (See page 5-3.)

TIP

When the vehicle is turned on, these lights should come on for a few seconds and then go off. Otherwise, have a Yamaha dealer check vehicle.

Engine trouble warning light

This warning light comes on if a problem is detected in the engine or other vehicle control system. If this occurs, have a Yamaha dealer check the on-board diagnostic system.

The electrical circuit of the warning light can be checked by turning the vehicle power on. The warning light should come on for a few seconds, and then go off.

If the warning light does not come on at all, or if the warning light remains on, have a Yamaha dealer check the vehicle.

ABS warning light “ABS”

EAU81910

In normal operation, the ABS warning light comes on when the main switch is turned to “ON”, and goes off after traveling at a speed of 10 km/h (6 mph) or higher.

EWA16041

WARNING

If the ABS warning light does not go off after traveling at a speed of 10 km/h (6 mi/h) or higher, or if the warning light comes on or flashes while riding, the brake system reverts to conventional braking. If either of the above occurs, or if the warning light does not come on at all, use extra caution to avoid possible wheel lock during emergency

braking. Have a Yamaha dealer check the brake system and electrical circuits as soon as possible.

Traction control system indicator light “TCS”

EAU8591

This indicator light will flash when traction control has engaged.

If the traction control system is turned off, this indicator light will come on. (See page 6-13.)

TIP

When the vehicle is turned on, the light should come on for a few seconds and then go off. If the light does not come on, or if the light remains on, have a Yamaha dealer check vehicle.

Smart key system indicator light “”

EAU81710

This indicator light communicates the status of the smart key system. When the smart key system is operating normally, this indicator light will be off. If there is an error in the smart key system, the indicator light will flash. The indicator light will also flash when com-

munication between the vehicle and smart key takes place and when certain smart key system operations are carried out.

TIP

After starting off, if the smart key cannot be detected (e.g., the smart key fell from your pocket), the smart key system indicator light will flash. Confirm the location and status of the smart key before proceeding further.

Alarm indicator light “” (Venture TC)

EAU81920

When the main switch is turned to “OFF” or “LOCK”, the alarm indicator light “” will come on for one minute, and then the anti-theft alarm is activated. The indicator light will begin flashing.

The electrical circuit of the indicator light can be checked by turning the main switch to “ON”. The indicator light should come on for a few seconds, and then go off.

Instrument and control functions

Tire pressure warning light “(U)”

EAU61930

This warning light comes on when the air pressure of a tire is low. Stop the motorcycle as soon as possible and inspect your tires. **WARNING! Failure to correct low tire pressure can lead to loss of control and serious injury.**

[EWA00420]

If a sensor battery is discharged or if a malfunction is detected, the warning light will flash. Have a Yamaha dealer check the vehicle.

The electrical circuit of the warning light can be checked by turning the main switch to “ON”. The warning light should come on for a few seconds, and then go off.

Speedometer and Tachometer

EAU61942

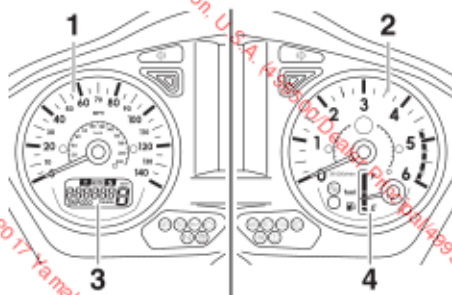

1. Speedometer
2. Tachometer
3. Tripmeter display
4. Fuel gauge

The speedometer and tachometer are also equipped with:

- a fuel gauge
- an odometer
- two tripmeters
- a fuel reserve tripmeter
- a drive mode display
- a transmission gear display
- an error code display

WARNING

Stop the vehicle before making any setting changes. Changing settings while riding can distract the operator and increase the risk of an accident.

Speedometer

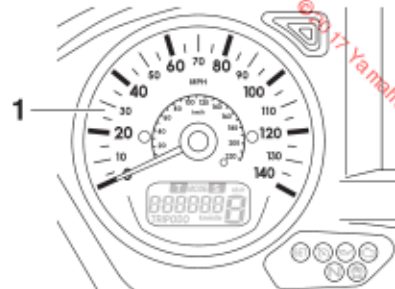

1. Speedometer

The speedometer shows the vehicle's traveling speed.

When the vehicle is turned on, the needle will sweep once across the speed range and then return to zero as a circuit self-check.

Instrument and control functions

Tachometer



1. Tachometer
2. Tachometer red zone

The tachometer shows engine speed in r/min. When the vehicle is turned on, the needle will sweep once across the r/min range and then return to zero as a circuit self-check.

ECA10032

NOTICE

Do not operate the engine in the tachometer red zone.

Red zone: 4750 r/min and above

Fuel gauge

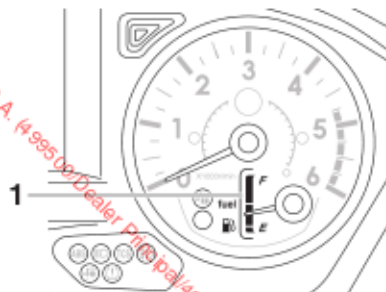

1. Fuel gauge

The fuel gauge needle moves from F (full) towards E (empty) as the fuel level decreases. When the needle reaches E, refuel as soon as possible.

When the vehicle is turned on, the needle will sweep once across the fuel level range and return to empty before indicating the current fuel amount.

Tripmeter display



1. Tripmeter display

The odometer, ODO shows the total distance traveled by the vehicle. The tripmeters TRIP 1 and TRIP 2 show the distance traveled since they were last reset. The fuel reserve tripmeter F TRIP shows the distance traveled on the fuel reserve.

TIP

- The odometer will lock at 999999.
- The tripmeters will reset and continue counting after 9999.9 is reached.
- The tripmeter display units can be switched between miles and kilometers via the infotainment system menus.

Instrument and control functions

Push the select/reset switch to change the display between the odometer mode ODO and the tripmeter modes TRIP 1 and TRIP 2 in the following order:

ODO → TRIP 1 → TRIP 2 → ODO

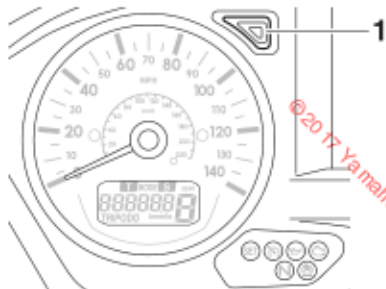

1. Select/reset switch

If the fuel level warning light comes on, the tripmeter display will automatically change to F TRIP and start counting the distance traveled from that point. In this case, push the select/reset switch to change the display in the following order:

F TRIP → TRIP 1 → TRIP 2 → ODO → F TRIP

To reset a tripmeter, select it by pushing the select/reset switch, and then push the select/reset switch for one second.

TIP

If you do not reset the fuel reserve tripmeter manually, it will reset automatically and disappear after refueling and traveling a few miles.

Drive mode display

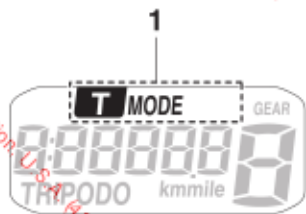

1. Drive mode display

The current drive mode is displayed: "T" for touring mode or "S" for sporty mode.

Transmission gear display

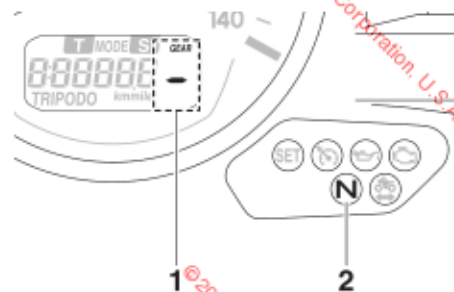

1. Transmission gear display
2. Neutral indicator light "N"

The current gear number is displayed, neutral is indicated by "-".

Error code display

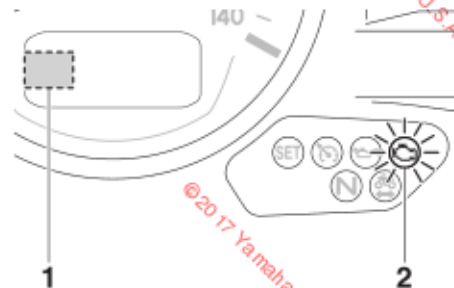

1. Error code display
2. Engine trouble warning light "C"

This model is equipped with a self-diagnosis device for various electrical circuits. If a problem is detected in any of those circuits, the engine trouble warning light will come on and the display will indicate an error code. If the display indicates any error codes, note the code number and have a Yamaha dealer check the vehicle.

ECA11581

NOTICE

If the display indicates an error code, the vehicle should be checked as soon as possible in order to avoid engine damage.

D-mode (drive mode)

D-mode is an electronically controlled engine performance system with two mode selections (touring mode "T" and sports mode "S").

Push the drive mode switch "MODE" to switch between modes. (See page 6-2 for an explanation of the drive mode switch.)



1. Drive mode switch "MODE"

TIP

Before using D-mode, make sure you understand its operation along with the operation of the drive mode switch.

Touring mode "T"

The touring mode "T" is suitable for various riding conditions.

This mode allows the rider to enjoy smooth drivability from the low-speed range to the high-speed range.

Sports mode "S"

This mode offers a sportier engine response in the low- to mid-speed range compared to the touring mode.

Instrument and control functions

EAU82260

Clutch lever

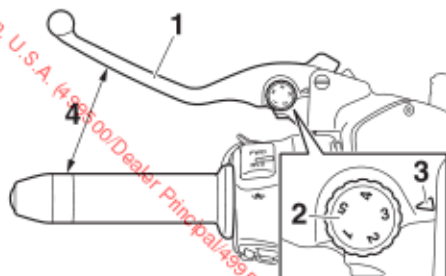

1. Clutch lever
2. Adjusting dial
3. "△" mark
4. Distance

Pull this lever to disengage the clutch. Release the lever to engage the clutch and transmit power to the rear wheel. The lever should be pulled rapidly and released slowly for smooth clutch operation. (See page 8-2.)

The position of the clutch lever can be adjusted. To adjust the distance between the clutch lever and the handlebar grip, push the lever away from the handlebar and turn the adjusting dial. Be sure the setting number aligns with the △ mark.

TIP

The clutch lever is equipped with a switch, which is part of the ignition circuit cut-off system. (See page 6-29.)

Shift pedal

EAU12872

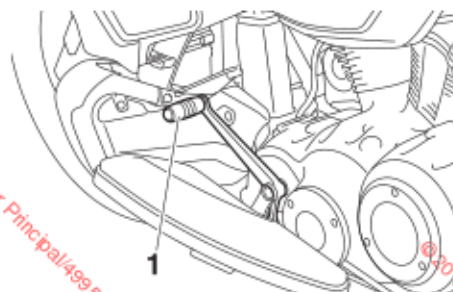

1. Shift pedal

The shift pedal is located on the left side of the motorcycle and is used in combination with the clutch lever when shifting the gears of the 6-speed constant-mesh transmission equipped on this motorcycle.

EAU81960

Brake lever

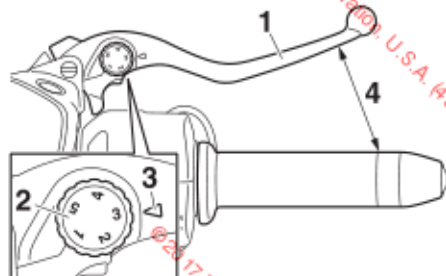

1. Brake lever
2. Adjusting dial
3. "△" mark
4. Distance

The brake lever is located on the right side of the handlebar. To apply the front brake, pull the lever toward the throttle grip.

This model is equipped with a unified brake system (UBS).

When pulling the brake lever, the front brake and a portion of the rear brake are applied. For full braking performance, apply both the brake lever and brake pedal simultaneously.

TIP

See **Brake system** for more information on how the UBS and ABS systems work.

The brake lever is equipped with a brake lever position adjusting dial. To adjust the distance between the brake lever and the throttle grip, turn the adjusting dial while holding the lever pushed away from the throttle grip. Make sure that the appropriate setting on the adjusting dial is aligned with the "△" mark on the brake lever.

EAU38542

Brake pedal

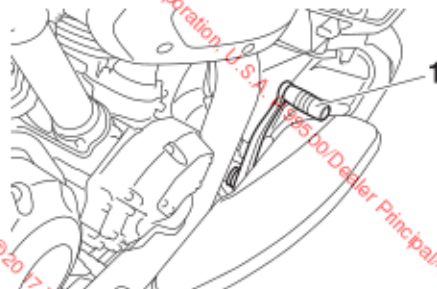

1. Brake pedal

The brake pedal is located on the right side of the vehicle.

This model is equipped with a unified brake system.

When pressing down on the brake pedal, the rear brake and a portion of the front brake are applied. For full braking performance, apply both the brake lever and the brake pedal simultaneously.

Instrument and control functions

Brake system

EAU82371

This model is equipped with an integrated anti-lock brake system (ABS) and a variable unified brake system (UBS).

Regarding ABS, operate the brakes as you would conventional brakes. When ABS engages, a pulsating sensation may be felt at the brake lever or brake pedal. In this situation, continue to apply the brakes and let the ABS work—do not pump the brakes as this will reduce braking effectiveness.

For full braking performance, apply both the brake lever and brake pedal simultaneously.

EWA19051

WARNING

Always keep a sufficient distance from the vehicle ahead to match the riding speed even with ABS.

- The ABS performs best with long braking distances.
- On certain surfaces, such as rough or gravel roads, the braking distance may be longer with the ABS than without.

Notes on usage

Regarding variable UBS, operating the brake lever will generate corresponding brake pressure at the front brake and to a variable degree, the rear brake. The amount of rear wheel braking force applied by the UBS is based on applied brake lever pressure. The reverse is also true for the brake pedal; however, the brake pedal effects front wheel braking via the right-side caliper only.

Basically, UBS functions when the vehicle is in motion. However, after coming to a stop while applying the brake lever or brake pedal, as long as that lever or pedal is continuously applied, UBS will remain engaged.

TIP

As further squeezing of the brake lever or brake pedal will not increase braking power, apply both the brake lever and brake pedal should further braking power be necessary—such as when stopping on a slope.

Sensors and control systems

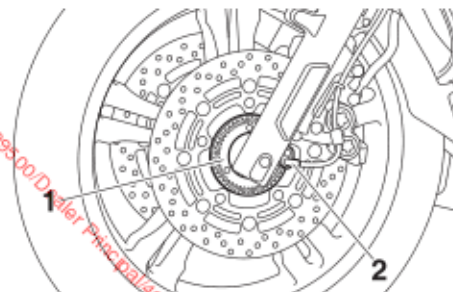

1. Front wheel sensor rotor
2. Front wheel sensor

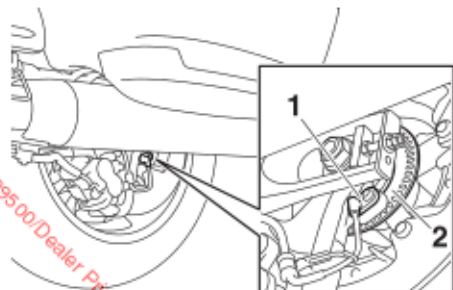

1. Rear wheel sensor
2. Rear wheel sensor rotor

The ABS and UBS hydraulic control unit is monitored by the ABS ECU, which will revert the system to conventional braking if a malfunction occurs.

TIP

- The ABS performs a self-test when the vehicle is started and reaches a speed of 10 km/h (6 mph). During this test, a clicking noise may be audible from the hydraulic control unit and a vibration may be felt at the brake lever or pedal, but this is normal.

NOTICE

Be careful not to damage the wheel sensor or wheel sensor rotor; otherwise, improper performance of the ABS will result.

Traction control system

The traction control system (TCS) helps maintain traction when accelerating on slippery surfaces, such as unpaved or wet roads. If sensors detect that the rear wheel is starting to slip (uncontrolled spinning), the traction control system assists by regulating engine power as needed until traction is restored.

TIP

- The TCS indicator light will flash to let you know that traction control has engaged.
- Slight changes in engine or exhaust sound may be noticeable.

WARNING

The traction control system is not a substitute for riding appropriately for the conditions. Traction control cannot prevent loss of traction due to excessive speed when entering turns, when accelerating hard at a sharp lean angle, or while braking, and cannot prevent front wheel slipping. As with any vehicle, approach

surfaces that may be slippery with caution and avoid especially slippery surfaces.

Turning TCS off or on

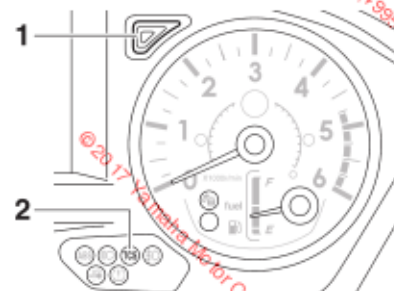

1. Traction control system switch
2. Traction control system indicator light "TCS"

When the main switch is turned to "ON", the traction control system automatically turns on.

To turn off the traction control system, stop the vehicle and push the traction control system switch for 2 seconds. The TCS indicator light will come on. To turn traction control back on, push the TCS switch again. The TCS indicator light will turn off.

Instrument and control functions

TIP

Turn off traction control to help free the rear wheel if stuck in mud, sand, or other situation.

Notes on usage

The traction control system will disable if:

- either wheel comes off the ground.
- excessive rear wheel spin is detected.
- either wheel is forcibly rotated (such as when performing maintenance).

TIP

If the traction control system is disabled, both the TCS indicator light and the engine trouble warning light will come on.

ECA16801

NOTICE

Use only the specified tires. (See page 9-17.) Using different sized tires will prevent the traction control system from controlling tire rotation accurately.

To reset the traction control system

1. Turn the main switch off and wait a few seconds.
2. Turn the main switch on and start the engine.
3. After traveling at least 20 km/h (12 mph), the TCS indicator light and the engine trouble warning light should turn off and the traction control system be enabled.

TIP

If the TCS indicator light or engine trouble warning light remain on after resetting, ride cautiously and have a Yamaha dealer check the vehicle as soon as possible.

EAJ77324

Fuel tank cap

To access the fuel tank, open the fuel tank cap lid. (See page 4-10.)

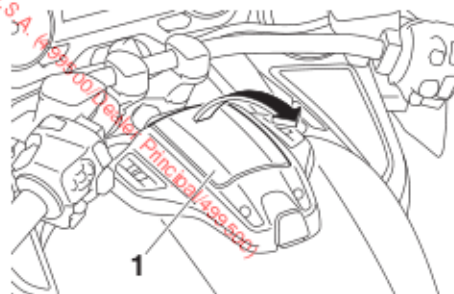

1. Fuel tank cap lid

To remove the fuel tank cap, press the lock release button and turn the fuel tank cap counterclockwise.

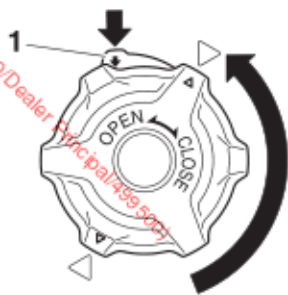

1. Lock release button

Instrument and control functions

To install the fuel tank cap, turn it clockwise until the lock release button pops out.

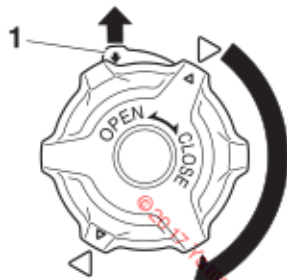

1. Lock release button

WARNING

Make sure that the fuel tank cap is properly installed and locked in place before operating the vehicle. Leaking fuel is a fire hazard.

Fuel

Make sure there is sufficient gasoline in the tank.

WARNING

Gasoline and gasoline vapors are extremely flammable. To avoid fires and explosions and to reduce the risk of injury when refueling, follow these instructions.

1. Before refueling, turn off the engine and be sure that no one is sitting on the vehicle. Never refuel while smoking, or while in the vicinity of sparks, open flames, or other sources of ignition such as the pilot lights of water heaters and clothes dryers.
2. Do not overfill the fuel tank. Stop filling when the fuel reaches the bottom of the filler tube. Because fuel expands when it heats up, heat from the engine or the sun can cause fuel to spill out of the fuel tank.

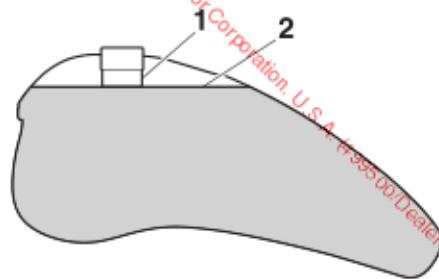

1. Fuel tank filler tube
2. Maximum fuel level

3. Wipe up any spilled fuel immediately. **NOTICE: Immediately wipe off spilled fuel with a clean, dry, soft cloth, since fuel may deteriorate painted surfaces or plastic parts.**
4. Be sure to securely close the fuel tank cap.

WARNING

Gasoline is poisonous and can cause injury or death. Handle gasoline with care. Never siphon gasoline by mouth. If you should swallow some gasoline or inhale a lot of gasoline vapor, or get some gasoline in your eyes, see your doctor immediately. If

Instrument and control functions

gasoline spills on your skin, wash with soap and water. If gasoline spills on your clothing, change your clothes.

EAU13384

Recommended fuel:

Premium unleaded gasoline (Gasohol [E10] acceptable)

Fuel tank capacity:

25 L (6.6 US gal, 5.5 Imp.gal)

Fuel reserve amount (when the fuel level warning light comes on):

3.6 L (0.95 US gal, 0.79 Imp.gal)

ECA11401

NOTICE

Use only unleaded gasoline. The use of leaded gasoline will cause severe damage to internal engine parts, such as the valves and piston rings, as well as to the exhaust system.

Your Yamaha engine has been designed to use premium unleaded gasoline with a pump octane number $[(R+M)/2]$ of 91 or higher, or a research octane number of 95 or higher. If knocking (or pinging) occurs, use a

gasoline of a different brand. Use of unleaded fuel will extend spark plug life and reduce maintenance costs.

Gasohol

There are two types of gasohol: gasohol containing ethanol and that containing methanol. Gasohol containing ethanol can be used if the ethanol content does not exceed 10% (E10). Gasohol containing methanol is not recommended by Yamaha because it can cause damage to the fuel system or vehicle performance problems.

Fuel tank overflow hose

EAU80200

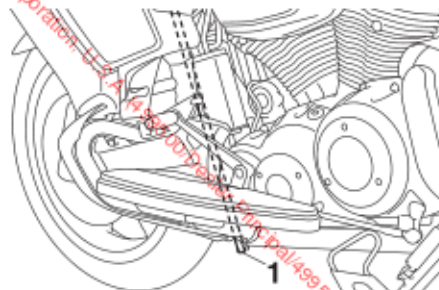

1. Fuel tank overflow hose

Before operating the vehicle:

- Check the fuel tank overflow hose connection.
- Check the fuel tank overflow hose for cracks or damage, and replace it if necessary.
- Make sure that the end of the fuel tank overflow hose is not blocked, and clean it if necessary.
- Make sure that the end of the fuel tank overflow hose is positioned as shown.

TIP

See page 9-12 for canister information.

EAU13447

ECA10702

EAU81991

Catalytic converters

This vehicle is equipped with catalytic converters in the exhaust system.

EWA10063

⚠ WARNING

The exhaust system is hot after operation. To prevent a fire hazard or burns:

- Do not park the vehicle near possible fire hazards such as grass or other materials that easily burn.
- Park the vehicle in a place where pedestrians or children are not likely to touch the hot exhaust system.
- Make sure that the exhaust system has cooled down before doing any maintenance work.
- Do not allow the engine to idle more than a few minutes. Long idling can cause a build-up of heat.

NOTICE

Use only unleaded gasoline. The use of leaded gasoline will cause unreparable damage to the catalytic converter.

Seat

To remove the seat

1. Remove panels A and B. (See page 9-9.)
2. Remove the bolts.

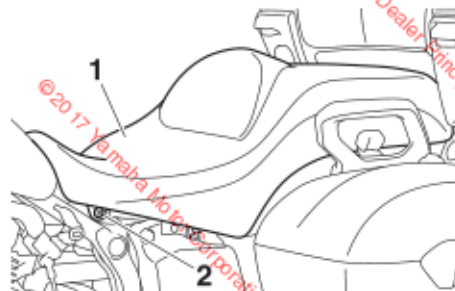

1. Seat
2. Bolt

Instrument and control functions

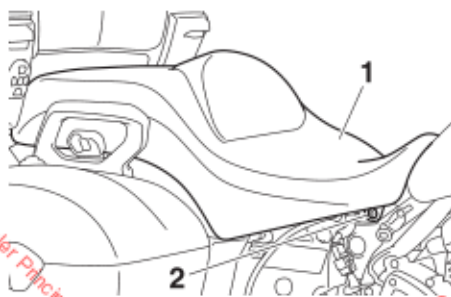

1. Seat
2. Bolt

3. Remove the lead from the holder and disconnect the coupler.

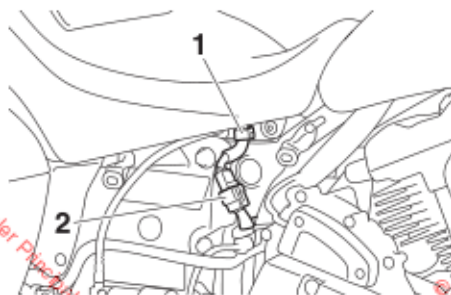

1. Holder
2. Coupler

4. Lift the front of the seat and pull it forward.

To install the seat

1. Insert the projections on the rear of the seat into the seat holders as shown.

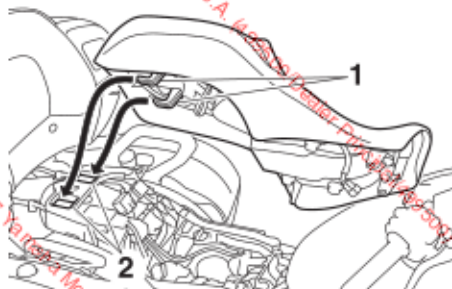

1. Projection
2. Seat holder

TIP

Make sure that the rider backrest lock release strap is positioned to the outside of the vehicle and is not trapped under the seat.

2. Connect the coupler and fasten the lead with the holder.
3. Install the bolts.
4. Install the panels.

TIP

Make sure that the seat is properly secured before riding.

To adjust the rider backrest forward or rearward

Pull the rider backrest lock release strap downward, and then move the rider backrest forward or rearward to the desired position.

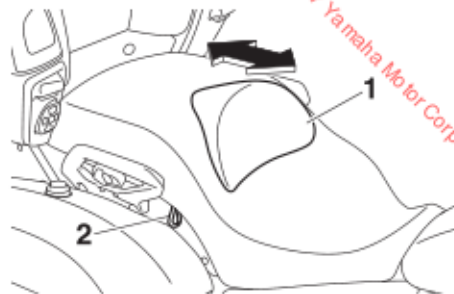

1. Rider backrest
2. Rider backrest lock release strap

Seat heater switch (passenger) “”

EAU82000

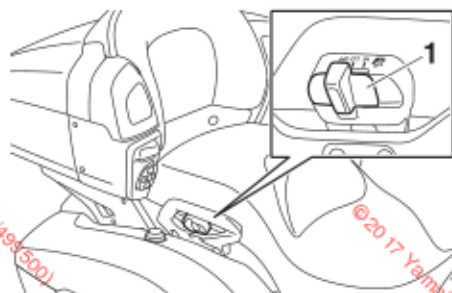

1. Seat heater switch (passenger) “”

The seat heater can be used when the main switch is in the “ON” position, but should only be used when the engine is running.

TIP

The temperature level for the “LO” and “HI” settings can be adjusted via the infotainment system.

The rider’s seat heater is also adjusted via the infotainment system.

Helmet holder

EAU82010

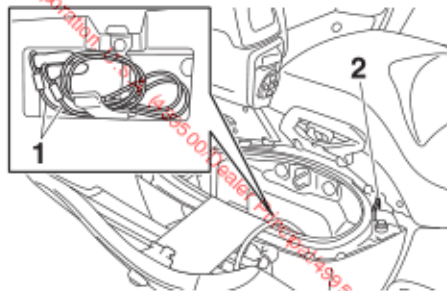

1. Helmet holding cable
2. Helmet holder

The helmet holder is located under the right saddlebag lid. Helmet holding cables are provided under the owner’s tool kit in the right saddlebag to secure helmets to the helmet holder.

To secure a helmet to the helmet holder

1. Open the right saddlebag. (See page 4-10.)
2. Pass a helmet holding cable through the buckle on the helmet strap as shown, and then hook the cable onto the helmet holder.



1. Helmet holding cable
2. Helmet

3. Close the right saddlebag, and then place the helmet on the seat. **WARNING! Never ride with a helmet attached to the helmet holder, since the helmet may hit objects, causing loss of control and possibly an accident.** [EWA10182]
NOTICE: Be sure to place the helmet on the seat. Some helmets may contact the muffler when placed on the right side of the vehicle because of their size or shape. [ECA26010]

Instrument and control functions

To release the helmet from the helmet holder

Open the right saddlebag, remove the helmet holding cable from the helmet holder and the helmet, and then close the saddlebag.

Storage compartments

This model is equipped with 5 storage compartments. The storage compartments are located as shown.

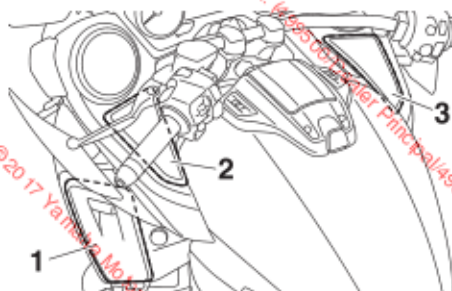

1. Storage compartment A
2. Storage compartment B
3. Storage compartment C

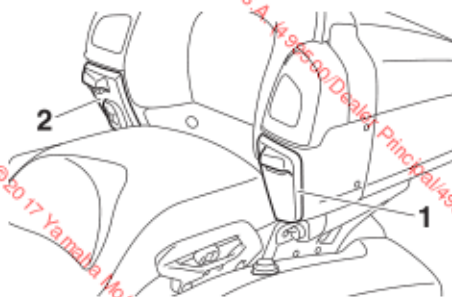

1. Storage compartment D (Venture TC)
2. Storage compartment E (Venture TC)

EAU82020

Storage compartment A

To open storage compartment A, while pulling the lever, pull the storage compartment lid as shown.

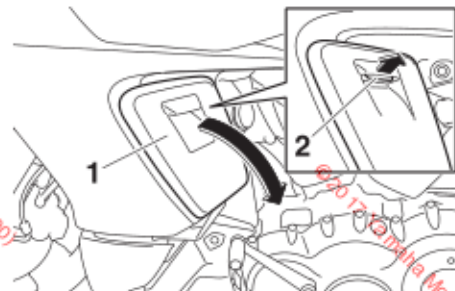

1. Storage compartment lid
2. Lever

To close the storage compartment, push the lid into the original position.

Storage compartment B

To open storage compartment B, push the storage compartment button to open the storage compartment lid.

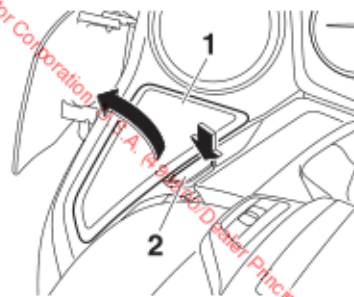

1. Storage compartment lid
2. Storage compartment button

To close storage compartment B, push the storage compartment lid until it is closed.

Storage compartment C

See page 4-10 to open and close storage compartment C.

Storage compartments D and E (Venture TC)

To open storage compartment D or E, while pulling the lever up, pull the storage compartment lid as shown.

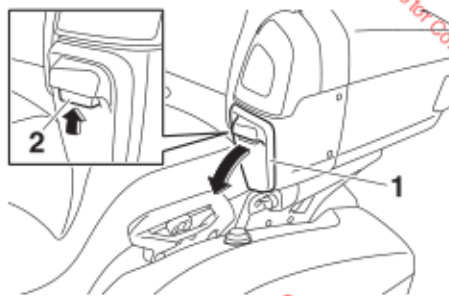

1. Storage compartment lid
2. Lever

To close the storage compartment, push the lid into the original position.

NOTICE

Keep the following points in mind when using a storage compartment.

- Since the storage compartment accumulates heat when exposed to the sun and/or the engine heat, do not store anything susceptible to heat, consumables or flammable items inside it.

- To avoid humidity from spreading through the storage compartment, wrap wet articles in a plastic bag before storing them in the compartment.
- Since the storage compartment may get wet while the vehicle is being washed, wrap any articles stored in the compartment in a plastic bag.
- Do not keep anything valuable or breakable in the storage compartment.

⚠ WARNING

Do not exceed the following loading limits:

- Storage compartment A: 1.0 kg (2 lb)
- Storage compartment B and C: 0.5 kg (1 lb)
- Storage compartment D and E: 0.5 kg (1 lb) (Venture TC)
- Maximum load for the vehicle: 185 kg (408 lb) (Venture TC) 188 kg (414 lb) (Venture)

EWA20383

Instrument and control functions

Windshield

EAU82030

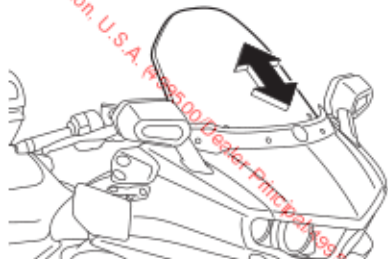

6 Use the windshield switches “” and “” to raise or lower the windshield.

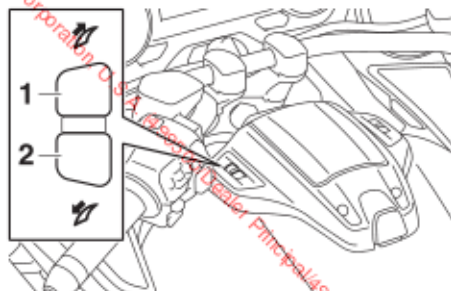

1. Windshield switch “”
2. Windshield switch “”

Push the up windshield switch to move the windshield all the way up (high position), or push the down switch to move the windshield all the way down (low position).

- Push the switch again to stop the windshield midway.
- The windshield high and low settings can be adjusted via the infotainment system display.
- The main switch must be in the “ON” position to raise or lower the windshield.

Rear view mirrors

EAU47261

The rear view mirrors of this vehicle can be folded forward for parking in narrow spaces. Fold the mirrors back to their original position before riding.

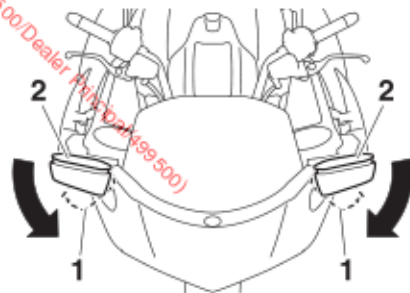

1. Parking position
2. Riding position

WARNING

Be sure to fold the rear view mirrors back to their original position before riding.

EWA14372

Saddlebags and Tour trunk

EAU82040

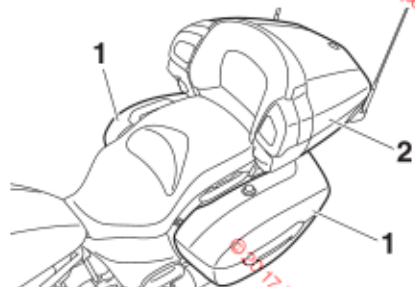

1. Saddlebag
2. Tour trunk

The saddlebag and tour trunk locks can be unlocked electronically or mechanically. See page 4-10 for information about unlocking the saddlebags and tour trunk electronically.

To unlock and open using a mechanical key

1. Remove the lock cylinder rubber cap.

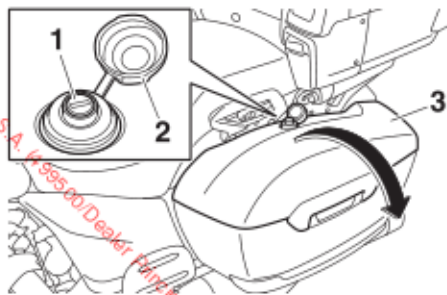

1. Saddlebag lock
2. Cap
3. Saddlebag lid

2. Insert the key into the lock, turn it counterclockwise, and then push in.

TIP

If the lock was already in the unlock position (from using the electronic lock system), first turn the key clockwise to the lock position before turning it counterclockwise.

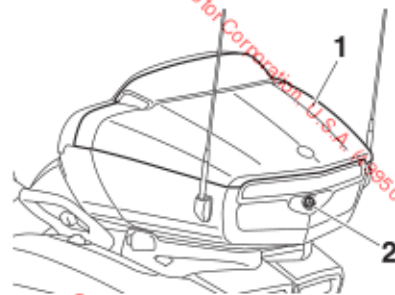

1. Tour trunk lid
2. Tour trunk lock

3. Open the lid of the saddlebag or tour trunk.

ECA13092

NOTICE

To avoid locking the key in, do not remove the key from the lock until after closing the lid.

To close and lock using a mechanical key

1. Return the lid to the original position, and then push it closed.
2. Insert the mechanical key and turn clockwise.

Instrument and control functions

TIP

The saddlebags and tour trunk cannot be unlocked electronically (via the unlock switch on unlock button on the fuel tank or smart key) if their locks were mechanically set to the lock position.

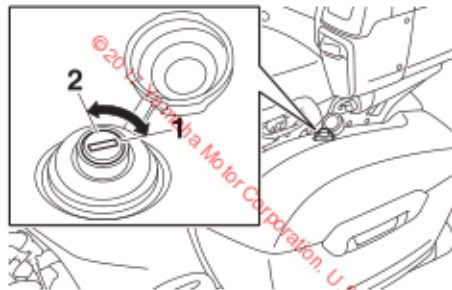

1. Lock.
2. Unlock.

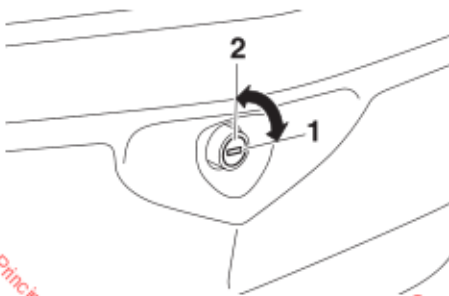

1. Lock.
2. Unlock.
3. Remove the key.

EWA20390

WARNING

Improper loading or overloading can cause loss of control and possibly an accident or personal injury. See pages 1-1 and 9-17 for important loading and tire pressure information.

- Always securely close the saddlebags and the tour trunk before riding.
- Distribute weight evenly on each side of the motorcycle.
- Do not exceed the load limit of 9.0 kg (20 lb) for each saddlebag and the tour trunk.

- Do not exceed the maximum load of 185 kg (408 lb) (Venture TC), 188 kg (414 lb) (Venture) for the vehicle.
- Do not exceed 120 km/h (80 mph) when riding with luggage in the saddlebags and the tour trunk, otherwise handling could be affected. Improper loading, poor tire or overall motorcycle conditions, poor road surfaces or adverse weather conditions may make it necessary to further reduce the riding speed.

Adjustable wind deflector

EAU82050

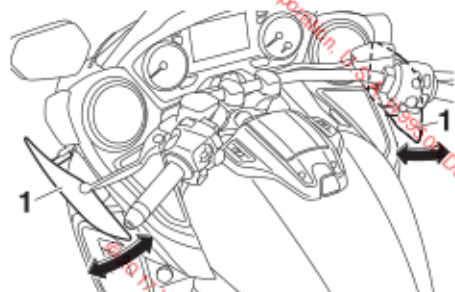

1. Adjustable wind deflector

Use the deflectors to adjust the airflow around the vehicle.

EWA20410

⚠ WARNING

Do not adjust the wind deflectors while the vehicle is in motion. You could lose control, have an accident or be injured.

Leg air vents

EAU82060

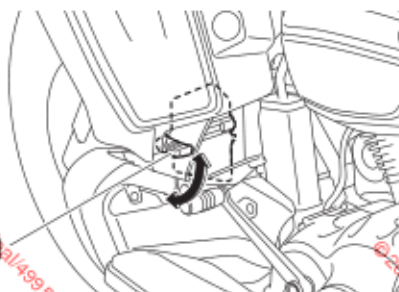

1. Leg air vent lever

The leg air vents are located to the front of the shift pedal and brake pedal. To open a leg air vent, lower the leg air vent lever. To close a leg air vent, raise the leg air vent lever.

Adjustable footrests

EAU82430

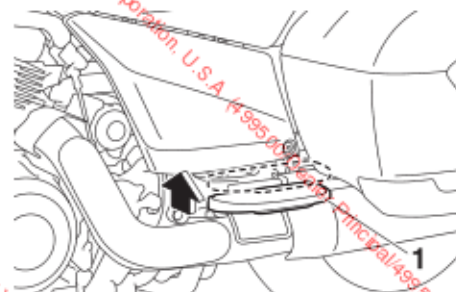

1. Passenger footrest

The passenger footrests can be adjusted. Contact your Yamaha dealer.

Instrument and control functions

Adjusting the shock absorber assembly

This shock absorber assembly is equipped with a spring preload adjuster.

NOTICE

To avoid damaging the mechanism, do not attempt to turn beyond the maximum or minimum settings.

To increase the spring preload and thereby harden the suspension, turn the adjuster in direction (a). To decrease the spring preload and thereby soften the suspension, turn the adjuster in direction (b).

Use the screwdriver included in the owner's tool kit to make this adjustment.

EAU62070

ECA10102

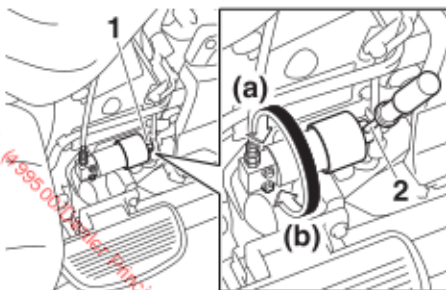

1. Rear shock absorber adjuster
2. Screwdriver

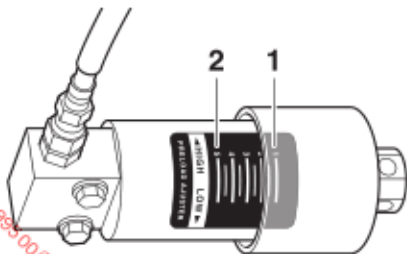

1. Minimum (soft)
2. Maximum (hard)

Spring preload setting:

Minimum (soft):

1 click(s) in direction (a)*

Standard:

7 click(s) in direction (a)*

Maximum (hard):

25 click(s) in direction (a)

* With the adjuster fully turned in direction (b)

TIP

To obtain a precise adjustment, it is advisable to check the actual total number of clicks of the spring preload adjuster. This adjustment range may not exactly match the specifications listed due to small differences in production.

EWA10222

WARNING

This shock absorber assembly contains highly pressurized nitrogen gas. Read and understand the following information before handling the shock absorber assembly.

- Do not tamper with or attempt to open the cylinder assembly.

- Do not subject the shock absorber assembly to an open flame or other high heat source. This may cause the unit to explode due to excessive gas pressure.
- Do not deform or damage the cylinder in any way. Cylinder damage will result in poor damping performance.
- Do not dispose of a damaged or worn-out shock absorber assembly yourself. Take the shock absorber assembly to a Yamaha dealer for any service.

Auxiliary DC jack

⚠ WARNING

To prevent electrical shock or short-circuiting, make sure that the cap is installed when the auxiliary DC jack is not being used.

NOTICE

The accessory connected to the auxiliary DC jack should not be used with the engine turned off, and the load must never exceed 60 W (5 A), otherwise the fuse may blow or the battery may discharge.

This vehicle is equipped with an auxiliary DC jack located next to storage compartment A.

A 12-V accessory connected to the auxiliary DC jack can be used when the main switch is in the "ON" position and should only be used when the engine is running.

To use the auxiliary DC jack

1. Turn the main switch to "OFF".
2. Remove the auxiliary DC jack cap.

EAU82080

EWX14361

ECA15432

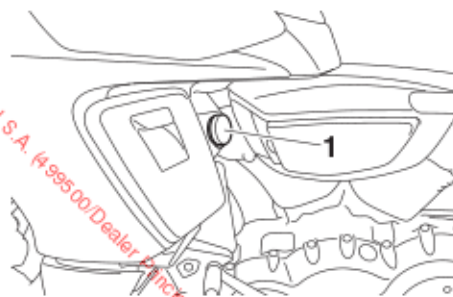

1. Auxiliary DC jack cap

3. Turn the accessory off.
4. Insert the accessory plug into the auxiliary DC jack.

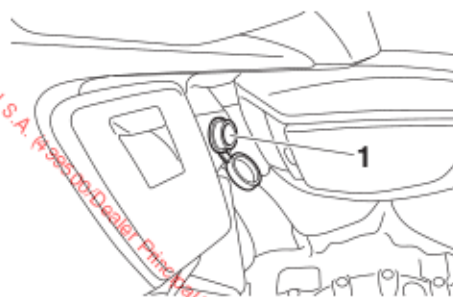

1. Auxiliary DC jack

5. Turn the main switch to "ON", and then start the engine. (See page 8-1.)
6. Turn the accessory on.

Instrument and control functions

Headset jacks

The vehicle is equipped with two headset jacks.

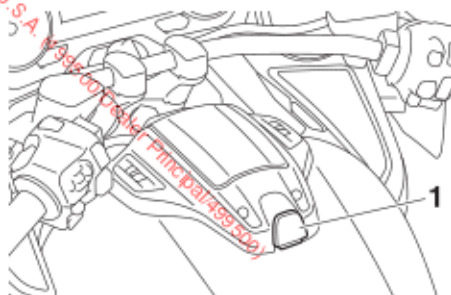

1. Rider headset jack

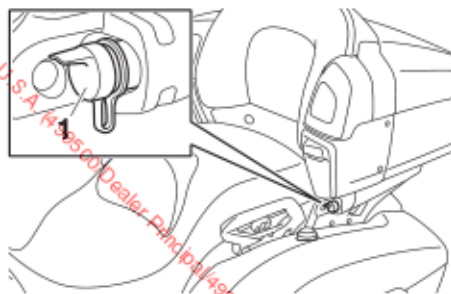

1. Passenger headset jack

EAU82090

Talk button (passenger) "📞"

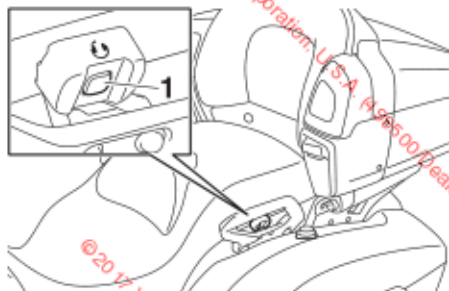

1. Talk button (passenger) "📞"

Push this button to start intercom communication with the rider. Push the button again to close the channel.

EAU82100

Audio controls (passenger)

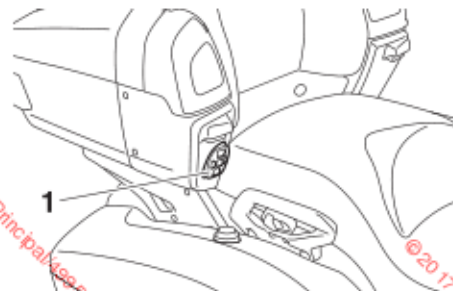

1. Audio controls (passenger)

These controls can be used to adjust the volume, and select a radio station, audio track or audio source. See the infotainment system owner's manual for more information.

EAU82110

EAU82530

Sidestand

The sidestand is located on the left side of the frame. Raise or lower the sidestand with your foot while holding the vehicle upright.

TIP

- The sidestand has a switch, which is part of the ignition circuit cut-off system and other vehicle control systems.
- If the engine is stopped by lowering the sidestand, a reminder alarm will sound. Turn off the main switch or raise the sidestand.

EWA10242

WARNING

The vehicle must not be ridden with the sidestand down, or if the sidestand cannot be properly moved up (or does not stay up), otherwise the sidestand could contact the ground and distract the operator, resulting in a possible loss of control. Yamaha's ignition circuit cut-off system has been designed to assist the operator in fulfilling the responsibility of raising the sidestand be-

fore starting off. Therefore, check this system regularly and have a Yamaha dealer repair it if it does not function properly.

EAU44894

Ignition circuit cut-off system

The ignition circuit cut-off system (comprising the sidestand switch, clutch switch and neutral switch) has the following functions.

- It prevents starting when the transmission is in gear and the sidestand is up, but the clutch lever is not pulled.
- It prevents starting when the transmission is in gear and the clutch lever is pulled, but the sidestand is still down.
- It cuts the running engine when the transmission is in gear and the sidestand is moved down.

Periodically check the operation of the ignition circuit cut-off system according to the following procedure.

Instrument and control functions

With the engine turned off:

1. Move the sidestand down.
2. Make sure that the engine stop switch is set to "O".
3. Turn the main switch on.
4. Shift the transmission into the neutral position.
5. Push the start switch.

Does the engine start?

YES

NO

With the engine still running:

6. Move the sidestand up.
7. Keep the clutch lever pulled.
8. Shift the transmission into gear.
9. Move the sidestand down.

Does the engine stall?

YES

NO

After the engine has stalled:

10. Move the sidestand up.
11. Keep the clutch lever pulled.
12. Push the start switch.

Does the engine start?

YES

NO

The system is OK. **The motorcycle can be ridden.**



WARNING

If a malfunction is noted, have a Yamaha dealer check the system before riding.

The neutral switch may not be working correctly.
The motorcycle should not be ridden until checked by a Yamaha dealer.

The sidestand switch may not be working correctly.
The motorcycle should not be ridden until checked by a Yamaha dealer.

The clutch switch may not be working correctly.
The motorcycle should not be ridden until checked by a Yamaha dealer.

For your safety – pre-operation checks

EAU15599

Inspect your vehicle each time you use it to make sure the vehicle is in safe operating condition. Always follow the inspection and maintenance procedures and schedules described in the Owner's Manual.

EWA11152

⚠ WARNING

Failure to inspect or maintain the vehicle properly increases the possibility of an accident or equipment damage. Do not operate the vehicle if you find any problem. If a problem cannot be corrected by the procedures provided in this manual, have the vehicle inspected by a Yamaha dealer.

Before using this vehicle, check the following points:

ITEM	CHECKS	PAGE
Fuel	<ul style="list-style-type: none">• Check fuel level in fuel tank.• Refuel if necessary.• Check fuel line for leakage.• Check fuel tank overflow hose for obstructions, cracks or damage, and check hose connection.	6-15, 6-16
Engine oil	<ul style="list-style-type: none">• Check oil level in oil tank.• If necessary, add recommended oil to specified level.• Check vehicle for oil leakage.	9-13
Front brake	<ul style="list-style-type: none">• Check operation.• If soft or spongy, have Yamaha dealer bleed hydraulic system.• Check brake pads for wear.• Replace if necessary.• Check fluid level in reservoir.• If necessary, add specified brake fluid to specified level.• Check hydraulic system for leakage.	9-22, 9-23

For your safety – pre-operation checks

ITEM	CHECKS	PAGE
Rear brake	<ul style="list-style-type: none"> • Check operation. • If soft or spongy, have Yamaha dealer bleed hydraulic system. • Check brake pads for wear. • Replace if necessary. • Check fluid level in reservoir. • If necessary, add specified brake fluid to specified level. • Check hydraulic system for leakage. 	9-22, 9-23
Clutch	<ul style="list-style-type: none"> • Check operation. • If soft or spongy, have Yamaha dealer bleed hydraulic system. • Check hydraulic system for leakage. 	9-20
Throttle grip	<ul style="list-style-type: none"> • Check for smooth rotation and automatic return. 	9-25
Wheels and tires	<ul style="list-style-type: none"> • Check wheels for damage. • Check overall condition and tread depth of tires. • Confirm tire air pressure with an air pressure gauge. 	9-17, 9-19
Brake and shift pedals	<ul style="list-style-type: none"> • Make sure that operation is smooth. • Lubricate pedal pivoting points if necessary. 	9-25
Brake and clutch levers	<ul style="list-style-type: none"> • Make sure that operation is smooth. • Lubricate lever pivoting points if necessary. 	9-26
Sidestand	<ul style="list-style-type: none"> • Make sure that operation is smooth. • Lubricate pivot if necessary. 	9-27
Chassis fasteners	<ul style="list-style-type: none"> • Make sure that all nuts, bolts and screws are properly tightened. • Tighten if necessary. 	—
Instruments, lights, signals and switches	<ul style="list-style-type: none"> • Check operation. • Correct if necessary. 	—
Sidestand switch	<ul style="list-style-type: none"> • Check operation of ignition circuit cut-off system. • If system is not working correctly, have Yamaha dealer check vehicle. 	6-29

EAU15952

Read the Owner's Manual carefully to become familiar with all controls. If there is a control or function you do not understand, ask your Yamaha dealer.

EWA10272

⚠ WARNING

Failure to familiarize yourself with the controls can lead to loss of control, which could cause an accident or injury.

EAU63621

TIP

This model is equipped with:

- a lean angle sensor to stop the engine in case of a turnover. In this case, the display will indicate error code 30, but this is not a malfunction. Turn the vehicle power off and then on to clear the error code. Failing to do so will prevent the engine from starting even though the engine will crank when pushing the start switch.
- an engine auto-stop system. The engine stops automatically if left idling for 20 minutes. If the engine stops, simply push the start switch to restart the engine.

EAU6331

Starting the engine

To start the engine, the transmission should be in neutral. To start the engine with the transmission in gear, the sidestand and SURE-PARK lever must be up and the clutch lever pulled. (See page 6-29.)

To start the engine

1. Turn the main switch on and set the engine stop switch to run. (See page 6-1.)
2. Confirm that the indicator and warning lights come on and go off as normal. (See page 6-3.)

WARNING! If an indicator light does not operate as designed, or if a warning light does not go off, check and rectify the cause immediately. [EWA20480]

3. In particular, confirm these warning lights are off:
 - Engine trouble warning light
 - Tire pressure warning light

Be aware that:

- Oil pressure warning light should go off after starting the engine.

Operation and important riding points

- ABS warning light should go off after traveling 10 km/h (6 mph).
4. Make sure the SURE-PARK lever is in its upright position, and the transmission is in neutral.
 5. Push the start switch and release it when the engine starts.
 - If the engine does not start, release the start switch after a few seconds.
 - Before pressing the start switch again, wait 10 seconds to allow battery voltage to restore.

NOTICE

8 For maximum engine life, never accelerate hard when the engine is cold!

Shifting

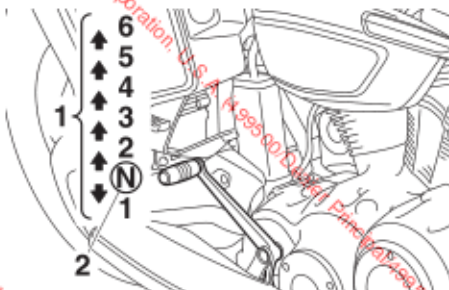

1. Gear positions
2. Neutral position

Shifting gears lets you control the amount of engine power available for starting off, accelerating, climbing hills, etc.

The gear positions are shown in the illustration.

TIP

To shift the transmission into the neutral position, press the shift pedal down repeatedly until it reaches the end of its travel, and then slightly raise it.

EAU19673

NOTICE

- Even with the transmission in the neutral position, do not coast for long periods of time with the engine off, and do not tow the motorcycle for long distances. The transmission is properly lubricated only when the engine is running. Inadequate lubrication may damage the transmission.
- Always use the clutch while changing gears to avoid damaging the engine, transmission, and drive train, which are not designed to withstand the shock of forced shifting.

ECA10261

To start out and accelerate

1. Pull the clutch lever to disengage the clutch.
2. Shift the transmission into first gear. The neutral indicator light should go out.
3. Open the throttle gradually, and at the same time, release the clutch lever slowly.

EAU16682

Operation and important riding points

EAU58200

- At the recommended shift points shown in the following table, close the throttle, and at the same time, quickly pull the clutch lever in.
- Shift the transmission into second gear. (Make sure not to shift the transmission into the neutral position.)
- Open the throttle part way and gradually release the clutch lever.
- Follow the same procedure when shifting to the next higher gear.

TIP

When shifting gears in normal operating conditions, use the recommended shift points.

EAU58270

To decelerate

- Release the throttle and apply both the front and the rear brakes smoothly to slow the motorcycle.
- At the recommended shift points shown in the following table, shift to a lower gear.
- When the motorcycle reaches 25 km/h (16 mph), the engine is about to stall or runs roughly, pull the

clutch lever in, use the brakes to slow the motorcycle, and continue to downshift as necessary.

- Once the motorcycle has stopped, the transmission can be shifted into the neutral position. The neutral indicator light should come on and then the clutch lever can be released.

WARNING

- Improper braking can cause loss of control or traction. Always use both brakes and apply them smoothly.**
- Make sure that the motorcycle and the engine have sufficiently slowed before shifting to a lower gear. Engaging a lower gear when the vehicle or engine speed is too high could make the rear wheel lose traction or the engine to over-rev. This could cause loss of control, an accident and injury. It could also cause engine or drive train damage.**

Eco shift points

The recommended shift points during acceleration and deceleration are shown in the table below.

Shift up points:

- 1st → 2nd: 20 km/h (12 mph)
- 2nd → 3rd: 30 km/h (19 mph)
- 3rd → 4th: 40 km/h (25 mph)
- 4th → 5th: 50 km/h (31 mph)
- 5th → 6th: 60 km/h (37 mph)

Shift down points:

- 6th → 5th: 45 km/h (28 mph)
- 5th → 4th: 35 km/h (22 mph)
- 4th → 3rd: 25 km/h (16 mph)

Operation and important riding points

Engine break-in

EAU16842

There is never a more important period in the life of your engine than the period between 0 and 1600 km (1000 mi). For this reason, you should read the following material carefully.

Since the engine is brand new, do not put an excessive load on it for the first 1600 km (1000 mi). The various parts in the engine wear and polish themselves to the correct operating clearances. During this period, prolonged full-throttle operation or any condition that might result in engine overheating must be avoided.

1600 km (1000 mi) and beyond

The vehicle can now be operated normally.

ECA10311

NOTICE

- Keep the engine speed out of the tachometer red zone.
- If any engine trouble should occur during the engine break-in period, immediately have a Yamaha dealer check the vehicle.

Parking

EAU82142

After finished parking or using the "ACC" position, turn both the vehicle and the smart key off.

TIP

Be sure to set the main switch to "OFF" or "LOCK" before leaving the vehicle.

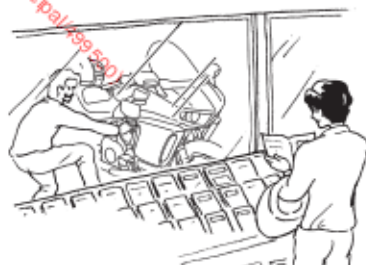

Even if the vehicle is parked behind a fence or you are inside a building, if the smart key is turned on and within proximity someone may be able to operate the main switch and start the engine. Turn the smart key off.

0-1000 km (0-600 mi)

Avoid prolonged operation above 2400 r/min. **NOTICE: After 1000 km (600 mi) of operation, the engine oil must be changed and the oil filter cartridge or element replaced.** [ECA10303]

1000-1600 km (600-1000 mi)

Avoid prolonged operation above 2900 r/min.

EWA10312

WARNING

- Since the engine and exhaust system can become very hot, park in a place where pedestrians or children are not likely to touch them and be burned.
- Do not park on a slope or on soft ground, otherwise the vehicle may overturn, increasing the risk of a fuel leak and fire.
- Do not park near grass or other flammable materials which might catch fire.

Periodic maintenance and adjustment

EAU17248

EWA15123

EAU17303

Periodic inspection, adjustment, and lubrication will keep your vehicle in the safest and most efficient condition possible. Safety is an obligation of the vehicle owner/operator. The most important points of vehicle inspection, adjustment, and lubrication are explained on the following pages.

The intervals given in the periodic maintenance charts should be simply considered as a general guide under normal riding conditions. However, depending on the weather, terrain, geographical location, and individual use, the maintenance intervals may need to be shortened.

EWA10322

EWA15461

WARNING

9 Failure to properly maintain the vehicle or performing maintenance activities incorrectly may increase your risk of injury or death during service or while using the vehicle. If you are not familiar with vehicle service, have a Yamaha dealer perform service.

WARNING

Turn off the engine when performing maintenance unless otherwise specified.

- **A running engine has moving parts that can catch on body parts or clothing and electrical parts that can cause shocks or fires.**
- **Running the engine while servicing can lead to eye injury, burns, fire, or carbon monoxide poisoning – possibly leading to death. See page 2-3 for more information about carbon monoxide.**

WARNING

Brake discs, calipers, drums, and linings can become very hot during use. To avoid possible burns, let brake components cool before touching them.

Emission controls not only function to ensure cleaner air, but are also vital to proper engine operation and maximum performance. In the following periodic maintenance charts, the services related to emissions control are grouped separately. These services require specialized data, knowledge, and equipment. Maintenance, replacement, or repair of the emission control devices and systems may be performed by any repair establishment or individual that is certified (if applicable). Yamaha dealers are trained and equipped to perform these particular services.

EAU82151

Owner's tool kit

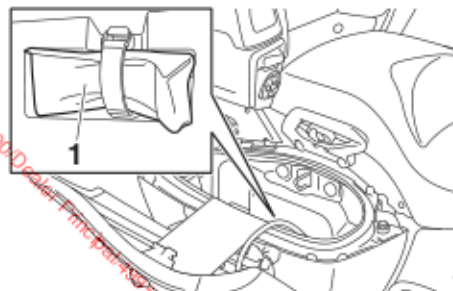

1. Owner's tool kit

The owner's tool kit is located inside the right saddlebag.

The information included in this manual and the tools provided in the tool kit are intended to assist you in the performance of preventive and regular maintenance. A service manual and other tools, such as a torque wrench, are necessary to perform more advanced maintenance and repair work correctly.

TIP

If you do not have the tools or experience required for a particular job, have your Yamaha dealer perform it for you.

Periodic maintenance and adjustment

EAU48491

TIP

- From 24000 mi (37000 km) or 36 months, repeat the maintenance intervals starting from 8000 mi (13000 km) or 12 months.
- Items marked with an asterisk require special tools, data and technical skills, have a Yamaha dealer perform the service.

Periodic maintenance chart for the emission control system

EAU17602

No.	ITEM	ROUTINE	INITIAL	ODOMETER READINGS				
			600 mi (1000 km) or 1 month	4000 mi (7000 km) or 6 months	8000 mi (13000 km) or 12 months	12000 mi (19000 km) or 18 months	16000 mi (25000 km) or 24 months	20000 mi (31000 km) or 30 months
1	* Fuel line	<ul style="list-style-type: none">• Check fuel hoses for cracks or damage.• Replace if necessary.		√	√	√	√	√
2	* Spark plugs	<ul style="list-style-type: none">• Check condition.• Adjust gap and clean.		√		√		√
		<ul style="list-style-type: none">• Replace.			√		√	
3	* Valve clearance	<ul style="list-style-type: none">• Check and adjust valve clearance when engine is cold.• Adjust if necessary.		Every 16000 mi (25000 km)				
4	* Crankcase breather system	<ul style="list-style-type: none">• Check breather hose for cracks or damage.• Replace if necessary.		√		√	√	
5	* Fuel injection	<ul style="list-style-type: none">• Adjust synchronization.		√	√	√	√	√

Periodic maintenance and adjustment

No.	ITEM	ROUTINE	INITIAL	ODOMETER READINGS				
			600 mi (1000 km) or 1 month	4000 mi (7000 km) or 6 months	8000 mi (13000 km) or 12 months	12000 mi (19000 km) or 18 months	16000 mi (25000 km) or 24 months	20000 mi (31000 km) or 30 months
6	Exhaust system	<ul style="list-style-type: none"> • Check for leakage. • Tighten if necessary. • Replace gasket(s) if necessary. 		✓	✓	✓	✓	✓
7	Evaporative emission control system	<ul style="list-style-type: none"> • Check control system for damage. • Replace if necessary. 				✓		✓
8	Air induction system	<ul style="list-style-type: none"> • Check the air cut-off valve, reed valve, and hose for damage. • Replace any damaged parts. 			✓		✓	

Periodic maintenance and adjustment

EAU67551

General maintenance and lubrication chart

No.	ITEM	ROUTINE	INITIAL	ODOMETER READINGS					
			600 mi (1000 km) or 1 month	4000 mi (7000 km) or 6 months	8000 mi (13000 km) or 12 months	12000 mi (19000 km) or 18 months	16000 mi (25000 km) or 24 months	20000 mi (31000 km) or 30 months	
1	Diagnostic system check	<ul style="list-style-type: none"> Perform dynamic inspection using Yamaha diagnostic tool. Check the error codes. 	√	√	√	√	√	√	
2	Air filter element	<ul style="list-style-type: none"> Replace. 	Every 24000 mi (37000 km)						
3	Clutch	<ul style="list-style-type: none"> Check operation, fluid level, and for fluid leakage. Correct if necessary. 	√	√	√	√	√	√	
4	Front brake	<ul style="list-style-type: none"> Check operation, fluid level, and for fluid leakage. Replace brake pads if necessary. 	√	√	√	√	√	√	
5	Rear brake	<ul style="list-style-type: none"> Check operation, fluid level, and for fluid leakage. Replace brake pads if necessary. 	√	√	√	√	√	√	
6	Brake hoses	<ul style="list-style-type: none"> Check for cracks or damage. Check for correct routing and clamping. 		√	√	√	√	√	
		<ul style="list-style-type: none"> Replace. 	Every 4 years						
7	Brake fluid	<ul style="list-style-type: none"> Change. 	Every 2 years						
8	Wheels	<ul style="list-style-type: none"> Check runout and for damage. Replace if necessary. 		√	√	√	√	√	

Periodic maintenance and adjustment

No.	ITEM	ROUTINE	INITIAL	ODOMETER READINGS					
			600 mi (1000 km) or 1 month	4000 mi (7000 km) or 6 months	8000 mi (13000 km) or 12 months	12000 mi (19000 km) or 18 months	16000 mi (25000 km) or 24 months	20000 mi (31000 km) or 30 months	
9	Tires	<ul style="list-style-type: none"> • Check tread depth and overall condition. • Replace if worn or damaged. • Confirm air pressure with an air pressure gauge. • Adjust air pressure as necessary. 		✓	✓	✓	✓	✓	✓
10	Wheel bearings	<ul style="list-style-type: none"> • Check bearings for smooth operation. • Replace if necessary. 		✓	✓	✓	✓	✓	✓
11	Swingarm pivot bearings	<ul style="list-style-type: none"> • Check bearing assemblies for looseness. 			✓				
		<ul style="list-style-type: none"> • Moderately repack with lithium-soap-based grease. 					✓		
12	Drive belt	<ul style="list-style-type: none"> • Check belt condition. • Replace if damaged. • Check belt tension. • Adjust if necessary. 	✓	Every 2500 mi (4000 km)					
13	Steering bearings	<ul style="list-style-type: none"> • Check bearing assemblies for looseness. 	✓	✓	✓	✓	✓	✓	✓
		<ul style="list-style-type: none"> • Moderately repack with lithium-soap-based grease. 	Every 16000 mi (25000 km)						
14	Chassis fasteners	<ul style="list-style-type: none"> • Check all chassis fitting and fasteners. • Correct if necessary. 		✓	✓	✓	✓	✓	✓
15	Brake lever pivot shaft	<ul style="list-style-type: none"> • Apply silicone grease lightly. 		✓	✓	✓	✓	✓	✓

Periodic maintenance and adjustment

No.	ITEM	ROUTINE	INITIAL	ODOMETER READINGS					
			600 mi (1000 km) or 1 month	4000 mi (7000 km) or 6 months	8000 mi (13000 km) or 12 months	12000 mi (19000 km) or 18 months	16000 mi (25000 km) or 24 months	20000 mi (31000 km) or 30 months	
16	Brake pedal pivot shaft	• Apply lithium-soap-based grease lightly.		√	√	√	√	√	√
17	Clutch lever pivot shaft	• Apply silicone grease lightly.		√	√	√	√	√	√
18	Shift pedal pivot shaft	• Apply lithium-soap-based grease lightly.		√	√	√	√	√	√
19	Sidestand pivot	• Check operation. • Apply lithium-soap-based grease lightly.		√		√	√	√	√
20	* Sidestand switch	• Check operation and replace if necessary.	√	√	√	√	√	√	√
21	* Front fork	• Check operation and for oil leakage. • Replace if necessary.		√	√	√	√	√	√
22	* Shock absorber assembly	• Check operation and for oil leakage. • Replace if necessary.		√	√	√	√	√	√
23	* Rear suspension link pivots	• Apply lithium-soap-based grease lightly.						√	
24	Engine oil	• Change (warm engine before draining).	√	√	√	√	√	√	√
25	* Engine oil filter cartridge	• Replace.	√					√	
26	* Front and rear brake switches	• Check operation.	√	√	√	√	√	√	√

Periodic maintenance and adjustment

No.	ITEM	ROUTINE	INITIAL	ODOMETER READINGS				
			600 mi (1000 km) or 1 month	4000 mi (7000 km) or 6 months	8000 mi (13000 km) or 12 months	12000 mi (19000 km) or 18 months	16000 mi (25000 km) or 24 months	20000 mi (31000 km) or 30 months
27	Throttle grip	<ul style="list-style-type: none"> Check operation. Lubricate throttle grip housing tube guides. 		√	√	√	√	√
28	Lights, signals and switches	<ul style="list-style-type: none"> Check operation. Adjust headlight beam 	√	√	√	√	√	√

EAU08M1

TIP

- Air filter
 - This model's air filter is equipped with a disposable oil-coated paper element, which must not be cleaned with compressed air to avoid damaging it.
 - The air filter element needs to be replaced more frequently when riding in unusually wet or dusty areas.
- Hydraulic brake and clutch systems
 - After disassembling the brake or clutch master cylinders, caliper cylinders or clutch release cylinder, always change the fluid. Regularly check the brake and clutch fluid levels and fill the reservoirs as required.
 - Replace the oil seals on the inner parts of the brake or clutch master cylinders, caliper cylinders and clutch release cylinder every two years.
 - Replace the brake and clutch hoses every four years or if cracked or damaged.

Periodic maintenance and adjustment

Removing and installing the cowling and panels

The cowling and panels shown need to be removed to perform some of the maintenance jobs described in this chapter. Refer to this section each time the cowling or a panel needs to be removed and installed.

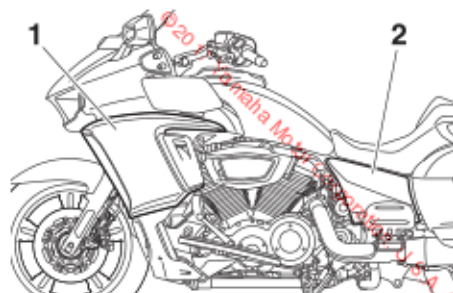

1. Cowling A
2. Panel A

EAU18724

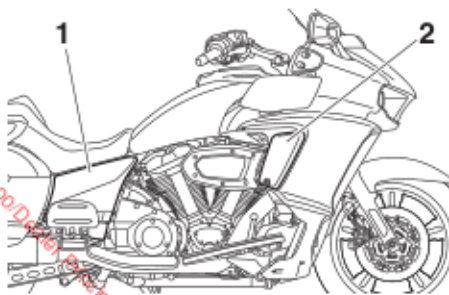

1. Panel B
2. Panel C

Cowling A

EAU82160

To remove the cowling

1. Open storage compartment A.
2. Remove the bolts.

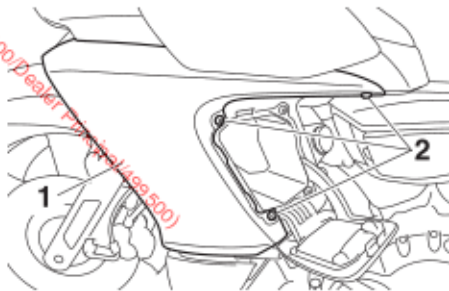

1. Cowling A
2. Bolt

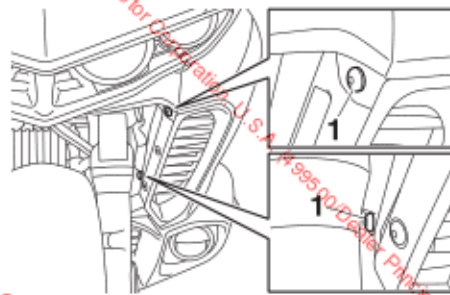

1. Bolt
3. Pull the cowling off as shown.

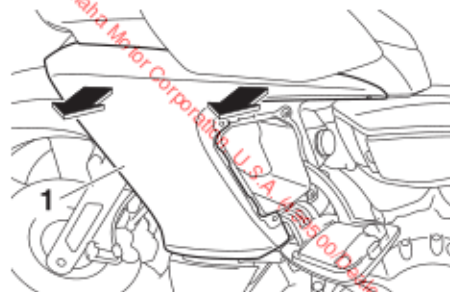

1. Cowling A

To install the cowling

1. Place the cowling in the original position.

Periodic maintenance and adjustment

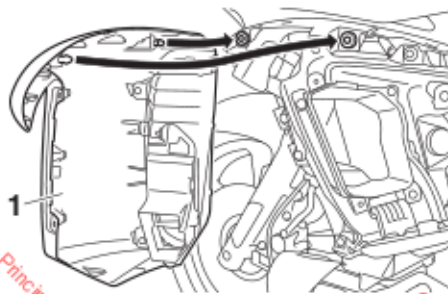

1. Cowling A
2. Install the bolts.
3. Close storage compartment A.

EAU82170

Panel A

To remove the panel, remove the bolt, and then pull the panel off as shown.

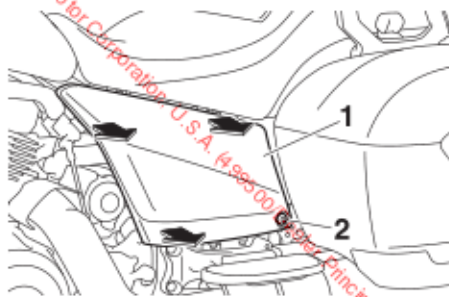

1. Panel A
2. Bolt

To install the panel, place the panel in the original position, and then install the bolts.

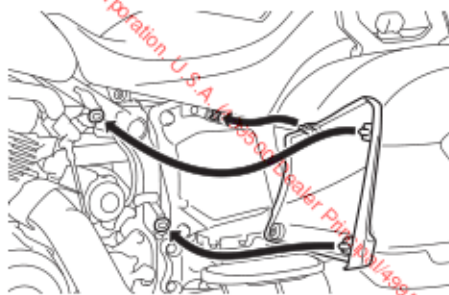

Panel B

To remove the panel, remove the quick fastener by turning it counterclockwise, and then pull the panel off as shown.

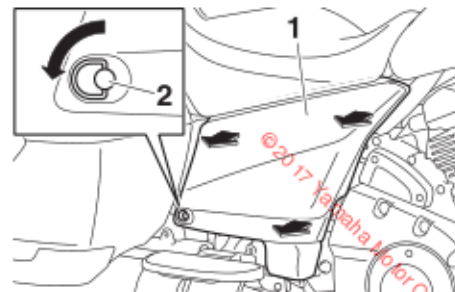

1. Panel B
2. Quick fastener

To install the panel, place the panel in the original position, and then install the quick fastener by turning it clockwise.

Periodic maintenance and adjustment

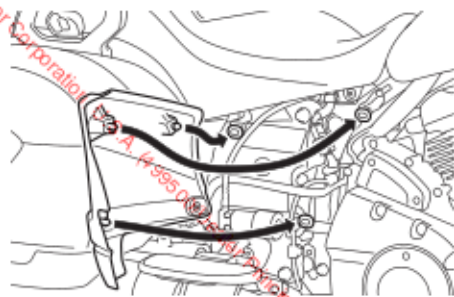

Panel C

To remove the panel, remove the quick fastener, and then pull the panel off as shown.

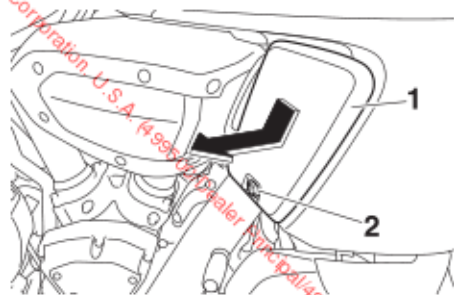

1. Panel C
2. Quick fastener

To install the panel, place the panel in the original position, and then install the quick fastener.

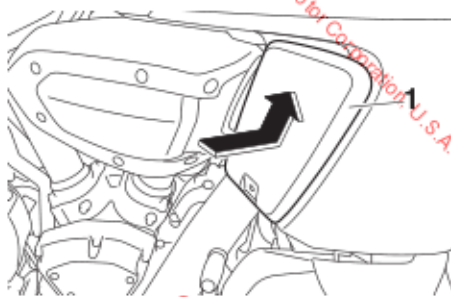

1. Panel C

Checking the spark plugs

EAU19843

The spark plugs are important engine components, which should be checked periodically, preferably by a Yamaha dealer. Since heat and deposits will cause any spark plug to slowly erode, they should be removed and checked in accordance with the periodic maintenance and lubrication chart. In addition, the condition of the spark plugs can reveal the condition of the engine.

The porcelain insulator around the center electrode of each spark plug should be a medium-to-light tan (the ideal color when the vehicle is ridden normally), and all spark plugs installed in the engine should have the same color. If any spark plug shows a distinctly different color, the engine could be operating improperly. Do not attempt to diagnose such problems yourself. Instead, have a Yamaha dealer check the vehicle.

If a spark plug shows signs of electrode erosion and excessive carbon or other deposits, it should be replaced.

Specified spark plug:
NGK/DPR7EA-9

Before installing a spark plug, the spark plug gap should be measured with a wire thickness gauge and, if necessary, adjusted to specification.

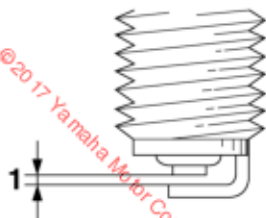

1. Spark plug gap

Spark plug gap:
0.8–0.9 mm (0.031–0.035 in)

Clean the surface of the spark plug gasket and its mating surface, and then wipe off any grime from the spark plug threads.

Tightening torque:
Spark plug:
18 N·m (1.8 kgf·m, 13 lb·ft)

TIP

If a torque wrench is not available when installing a spark plug, a good estimate of the correct torque is 1/4–1/2 turn past finger tight. However, the spark plug should be tightened to the specified torque as soon as possible.

Canister

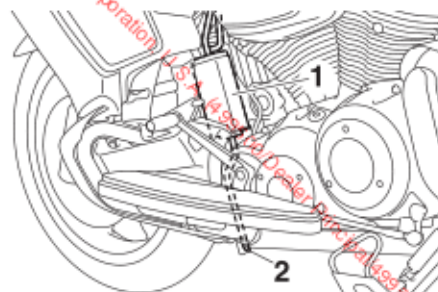

1. Canister
2. Canister breather hose

This model is equipped with a canister to prevent the discharging of fuel vapor into the atmosphere. Before operating this vehicle, make sure to check the following:

- each hose connection, tighten if loose.
- each hose and the canister body for damage, replace if damaged.
- the canister breather hose is not blocked off, clean if necessary.

Periodic maintenance and adjustment

Engine oil and oil filter cartridge

The engine oil level should be checked before each ride. In addition, the oil must be changed and the oil filter cartridge replaced at the intervals specified in the periodic maintenance and lubrication chart.

For oil specifications, see page 11-1.

NOTICE

- In order to prevent clutch slippage (since the engine oil also lubricates the clutch), do not mix any chemical additives. Do not use oils with a diesel specification of "CD" or oils of a higher quality than specified. In addition, do not use oils labeled "ENERGY CONSERVING II" or higher.
- Make sure that no foreign material enters the oil tank.

To check the engine oil level

1. With the vehicle on its sidestand, start the engine and allow it to warm up.

2. Stop the engine and wait a few minutes to allow the oil to settle.
3. Open the left saddlebag.
4. With the vehicle held upright on a level surface (the sidestand will give a false reading), remove the engine oil dipstick, wipe it clean, and then insert it back into the hole (without screwing it in).
5. Remove the dipstick and check the oil level.

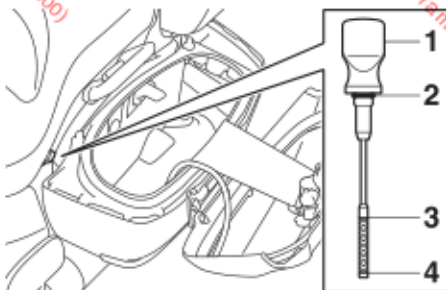

1. Engine oil dipstick
2. O-ring
3. Maximum level mark
4. Minimum level mark

TIP

- Confirm the oil level is between the maximum and minimum marks.

- Check the dipstick o-ring for damage, and replace it if necessary.
6. If the engine oil is at or below the minimum level mark, remove the seat, remove the oil tank filler cap, and then add oil (see page 11-1) to raise it to the correct level.

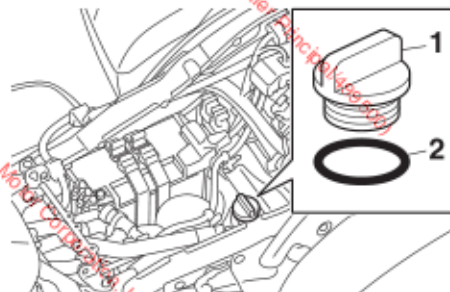

1. Oil tank filler cap
2. O-ring

TIP

- When adding oil, be careful not to overfill the engine oil tank—the oil level rises faster as it fills up.
 - Check the filler cap o-ring for damage, and replace it if necessary.
7. Insert and tighten the engine oil dipstick and the oil tank filler cap.

Periodic maintenance and adjustment

- Close the left saddlebag.
- Install the seat.

ECA10901

NOTICE

Make sure that the oil filler cap is securely tightened, otherwise oil may seep out when the engine is running.

To change the engine oil

If the engine is cold, run the engine for a few minutes to warm up the engine oil.

- Remove the seat and oil tank filler cap.
- Place an oil pan under the oil tank.
- Remove the oil tank drain bolt and its gasket.

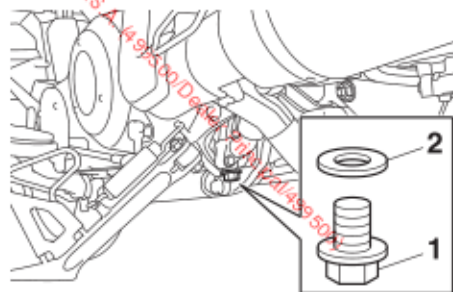

- Engine oil drain bolt (oil tank)
- Gasket

- Remove the crankcase filler bolt and inspect the o-ring.

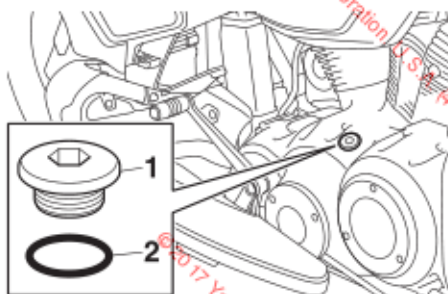

- Crankcase filler bolt
- O-ring

- Place an oil pan under the crankcase.
- Remove engine oil drain bolts A and B and their gaskets.

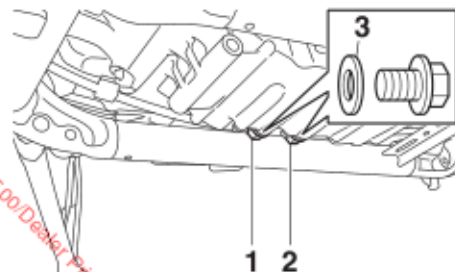

- Engine oil drain bolt A (crankcase)
- Engine oil drain bolt B (crankcase)
- Gasket

TIP

Skip steps 7-9 if the oil filter cartridge is not being replaced.

- Remove the oil filter cartridge.

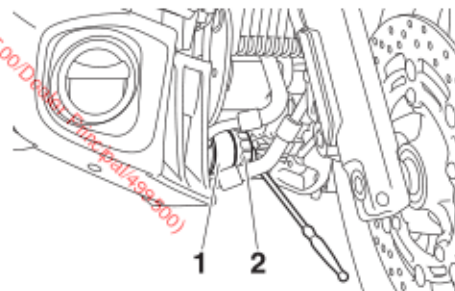

- Oil filter cartridge
- Oil filter wrench

Periodic maintenance and adjustment

TIP

An oil filter wrench is available at a Yamaha dealer.

8. Apply a thin coat of clean engine oil to the o-ring of the new oil filter cartridge.

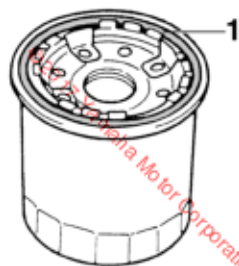

1. O-ring

TIP

Make sure the o-ring is properly seated.

9. Install the new oil filter cartridge, and then tighten it to the specified torque.

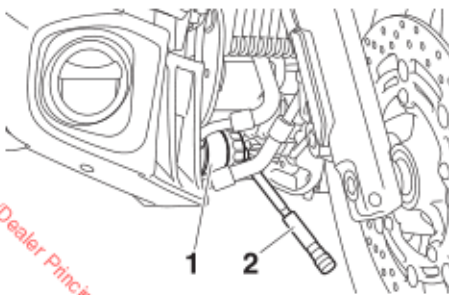

1. Oil filter cartridge
2. Torque wrench

Tightening torque:

Oil filter cartridge:
17 N·m (1.7 kgf·m, 13 lb-ft)

10. Install the engine oil drain bolts and new gaskets, and then tighten to the specified torque.

Tightening torques:

Engine oil drain bolt A (crankcase):
32 N·m (3.2 kgf·m, 24 lb-ft)
Engine oil drain bolt B (crankcase):
32 N·m (3.2 kgf·m, 24 lb-ft)
Engine oil drain bolt (oil tank):
32 N·m (3.2 kgf·m, 24 lb-ft)

11. Pour 1.9 L (2.0 US qt, 1.7 Imp.qt) of engine oil into the crankcase.

12. Install the crankcase filler bolt and o-ring.
13. Pour approximately 3.0 L (3.2 US qt, 2.6 Imp.qt) of engine oil into the oil tank.

TIP

- Fill the oil tank gradually while checking the oil level on the dipstick.
- The necessary quantity of oil will increase slightly if the oil filter was also changed.

14. Install the oil tank filler cap and the engine oil dipstick.
15. Start the engine and let it idle for several minutes while checking for oil leakage.

TIP

If oil is leaking or the oil pressure warning light stays on, stop the engine and check for the cause.

16. Turn the engine off and check the oil level one last time.
17. Close the left saddlebag and install the seat.

18. Reset any maintenance items via the infotainment system touchscreen.

EAU47061

Replacing the air filter element

The air filter element should be replaced at the intervals specified in the periodic maintenance and lubrication chart. Replace the air filter element more frequently if you are riding in unusually wet or dusty areas.

To replace the air filter element

1. Remove the air filter case cover by removing the bolts.

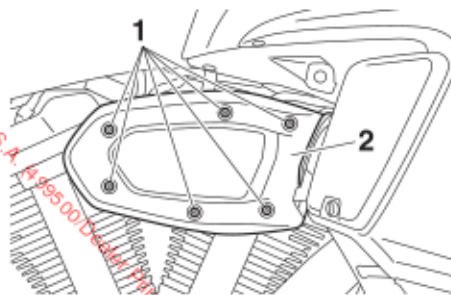

1. Bolt
2. Air filter case cover

2. Pull the air filter element out.

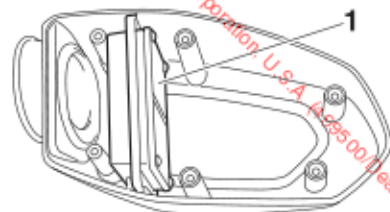

1. Air filter element

3. Insert a new air filter element into the air filter case. **NOTICE: Make sure that the air filter element is properly seated in the air filter case. The engine should never be operated without the air filter element installed, otherwise the piston(s) and/or cylinder(s) may become excessively worn.**

[ECA1048Z]

4. Install the air filter case cover by installing the bolts.

Periodic maintenance and adjustment

Checking the engine idling speed

Check the engine idling speed and, if necessary, have it corrected by a Yamaha dealer.

Engine idling speed:
900–1000 r/min

EAU44735

Valve clearance

The valve clearance changes with use, resulting in improper air-fuel mixture and/or engine noise. To prevent this from occurring, the valve clearance must be adjusted by a Yamaha dealer at the intervals specified in the periodic maintenance and lubrication chart.

EAU21402

Tires

Tires are the only contact between the vehicle and the road. Safety in all conditions of riding depends on a relatively small area of road contact. Therefore, it is essential to maintain the tires in good condition at all times and replace them at the appropriate time with the specified tires.

EAU82500

Tire air pressure

The tire air pressure should be checked with an air pressure gauge and, if necessary, adjusted before each ride.

EWA18130

WARNING

Operation of this vehicle with improper tire pressure may cause severe injury or death from loss of control.

- Tire inflation pressure should be checked and adjusted when the temperature of the tire equals the ambient air temperature.
- Tire inflation pressure must be adjusted according to the weight of cargo, rider, passen-

Periodic maintenance and adjustment

EWA10583

ger, and accessories (windshield, sidebags, etc. if approved for this model).

Tire air pressure (measured on cold tires):

Up to 90 kg (198 lb) load:

Front:

280 kPa (2.80 kgf/cm², 41 psi)

Rear:

280 kPa (2.80 kgf/cm², 41 psi)

90 kg (198 lb) to maximum load:

Front:

280 kPa (2.80 kgf/cm², 41 psi)

Rear:

280 kPa (2.80 kgf/cm², 41 psi)

Maximum load*:

185 kg (408 lb) (Venture TC)

188 kg (414 lb) (Venture)

* Total weight of rider, passenger, cargo and accessories

EWA10512

WARNING

Never overload your vehicle. Operation of an overloaded vehicle could cause an accident.

Tire inspection

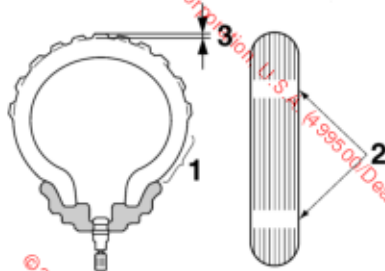

1. Tire sidewall
2. Tire wear indicator
3. Tire tread depth

The tires must be checked before each ride. If a tire tread shows crosswise lines (minimum tread depth), if the tire has a nail or glass fragments in it, or if the sidewall is cracked, contact a Yamaha dealer immediately and have the tire replaced.

Minimum tire tread depth (front and rear):

1.0 mm (0.04 in)

WARNING

- It is dangerous to ride with a worn-out tire. When a tire tread begins to show crosswise lines, have a Yamaha dealer replace the tire immediately.
- The replacement of all wheel and brake-related parts, including the tires, should be left to a Yamaha dealer, who has the necessary professional knowledge and experience to do so.
- Ride at moderate speeds after changing a tire since the tire surface must first be “broken in” for it to develop its optimal characteristics.

Tire information

This model is equipped with tubeless tires.

Tires age, even if they have not been used or have only been used occasionally. Cracking of the tread and sidewall rubber, sometimes accompanied by carcass deformation, is an evidence of

Periodic maintenance and adjustment

ageing. Old and aged tires shall be checked by tire specialists to ascertain their suitability for further use.

EWA10482

WARNING

The front and rear tires should be of the same make and design, otherwise the handling characteristics of the vehicle may be different, which could lead to an accident.

After extensive tests, only the tires listed below have been approved for this model by Yamaha.

Front tire:

Size:

130/70R18M/C63H

Manufacturer/model:

BRIDGESTONE/G853 RADIAL J
(T/L)

Rear tire:

Size:

200/55R16M/C-77H

Manufacturer/model:

BRIDGESTONE/G852 RADIAL J
(T/L)

Cast wheels

To maximize the performance, durability, and safe operation of your vehicle, note the following points regarding the specified wheels.

- The wheel rims should be checked for cracks, bends, warpage or other damage before each ride. If any damage is found, have a Yamaha dealer replace the wheel. Do not attempt even the smallest repair to the wheel. A deformed or cracked wheel must be replaced.
- The wheel should be balanced whenever either the tire or wheel has been changed or replaced. An unbalanced wheel can result in poor performance, adverse handling characteristics, and a shortened tire life.
- After repairing or replacing the rear tire, tighten the valve stem nut and locknut to the specified torques.

EAU21996

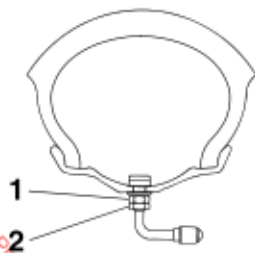

1. Valve stem nut
2. Valve stem locknut

Tightening torques:

Valve stem nut:

2.0 N·m (0.20 kgf·m, 1.5 lb·ft)

Valve stem locknut:

3.0 N·m (0.30 kgf·m, 2.2 lb·ft)

TPMS

EAU82481



1. TPMS sensor

This model is equipped with a tire pressure monitoring system (TPMS). If low tire-pressure is detected, the “(1)” indicator light will come on.

TIP

If a sensor battery is discharged or if a malfunction is detected, the warning light will flash.

ECA26090

NOTICE

To avoid damaging the TPMS sensors, have your tires professionally serviced by your Yamaha dealer.

Part 15 of FCC Rules

This device complies with Part 15 of FCC Rules. Operation is subject to the following two conditions:

- (1) this device may not cause interference, and
- (2) this device must accept any interference, including interference that may cause undesired operation of this device.

FCC WARNING

Changes or modifications not expressly approved by the party responsible for compliance could void the user's authority to operate the equipment.

Clutch lever

Since this model is equipped with a hydraulic clutch, adjusting the clutch lever free play is not needed. However, it is necessary to check the hydraulic system for leakage before each ride. If the clutch lever free play does become excessive, and shifting becomes rough or clutch slippage occurs, causing poor acceleration, there may be air in the clutch system. If there is air in the hydraulic system, have a Yamaha dealer bleed the system before operating the motorcycle.

EAU42851

Periodic maintenance and adjustment

Checking the brake lever free play

EAU37914

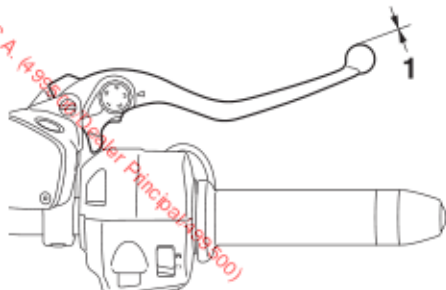

1. No brake lever free play

There should be no free play at the brake lever end. If there is free play, have a Yamaha dealer inspect the brake system.

EWA14212

WARNING

9 A soft or spongy feeling in the brake lever can indicate the presence of air in the hydraulic system. If there is air in the hydraulic system, have a Yamaha dealer bleed the system before operating the vehicle. Air in the hydraulic system will diminish the

braking performance, which may result in loss of control and an accident.

Brake light switches

EAU36505

The brake light should come on just before braking takes effect. The brake light is activated by switches connected to the brake lever and brake pedal. Since the brake light switches are components of the anti-lock brake system, they should only be serviced by a Yamaha dealer.

Checking the front and rear brake pads

EAU22383

The front and rear brake pads must be checked for wear at the intervals specified in the periodic maintenance and lubrication chart.

Front brake pads

EAU22360

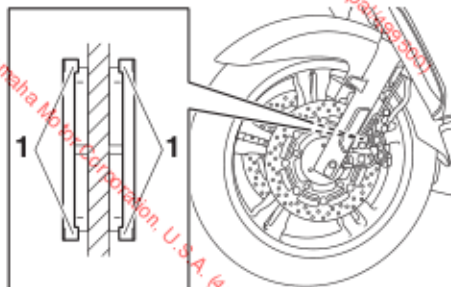

1. Brake pad wear indicator

The front brake pads have wear indicators, which allows you to check brake pad wear without having to disassemble the calipers. To check brake pad wear, apply the front brake and check the position of the wear indicators. If a brake pad has worn to the point that a wear indicator almost

touches the brake disc, have a Yamaha dealer replace the brake pads as a set.

TIP

The rear brake pedal effects front braking via the right-side caliper.

- The right-side caliper brake pads may wear sooner than the left.
- Always check the left and right-side calipers independently.

thickness is less than 1.0 mm (0.04 in), have a Yamaha dealer replace the brake pads as a set.

Rear brake pads

EAU22501

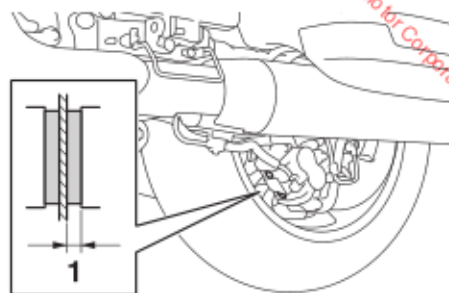

1. Lining thickness

Check each rear brake pad for damage and measure the lining thickness. If a brake pad is damaged or if the lining

Periodic maintenance and adjustment

Checking the brake fluid level

EAU40262

Before riding, check that the brake fluid is above the minimum level mark. Check the brake fluid level with the top of the reservoir level. Replenish the brake fluid if necessary.

Front brake

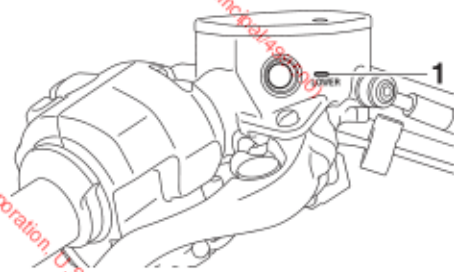

1. Minimum level mark

Rear brake

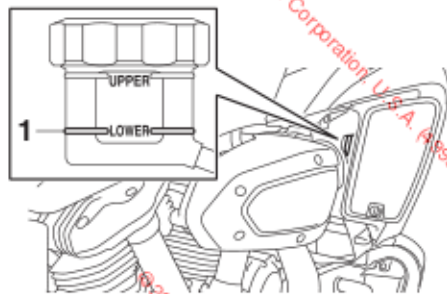

1. Minimum level mark

Specified brake fluid:
DOT 4

EWA16011

⚠ WARNING

Improper maintenance can result in loss of braking ability. Observe these precautions:

- Insufficient brake fluid may allow air to enter the brake system, reducing braking performance.
- Clean the filler cap before removing. Use only DOT 4 brake fluid from a sealed container.

- Use only the specified brake fluid; otherwise, the rubber seals may deteriorate, causing leakage.
- Refill with the same type of brake fluid. Adding a brake fluid other than DOT 4 may result in a harmful chemical reaction.
- Be careful that water or dust does not enter the brake fluid reservoir when refilling. Water will significantly lower the boiling point of the fluid and may result in vapor lock, and dirt may clog the ABS hydraulic unit valves.

NOTICE

Brake fluid may damage painted surfaces or plastic parts. Always clean up spilled fluid immediately.

As the brake pads wear, it is normal for the brake fluid level to gradually go down. A low brake fluid level may indicate worn brake pads and/or brake system leakage; therefore, be sure to check the brake pads for wear and the brake system for leakage. If the brake

ECA17641

fluid level goes down suddenly, have a Yamaha dealer check the cause before further riding.

Changing the brake and clutch fluids

Have a Yamaha dealer change the brake and clutch fluids at the intervals specified in the periodic maintenance and lubrication chart. In addition, have the oil seals of the brake and clutch master cylinders and calipers as well as the brake and clutch hoses replaced at the intervals listed below or whenever they are damaged or leaking.

- Oil seals: Replace every two years.
- Brake and clutch hoses: Replace every four years.

EAU22754

EAU23041

Drive belt slack

The drive belt slack should be checked and adjusted at the intervals specified in the periodic maintenance and lubrication chart.

EAU55773

To check the drive belt slack

1. Place the vehicle on the side-stand.
2. Note the current position of the drive belt using the marks near the drive belt check hole.

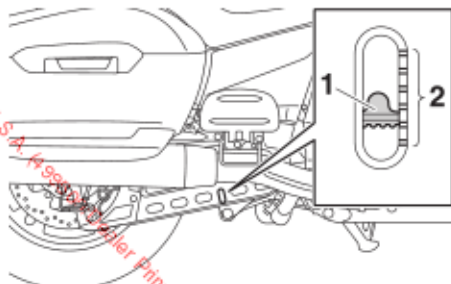

1. Drive belt
2. Marks

3. Note the position of the drive belt with a force of 45 N (4.5 kgf, 10 lbf) applied to the belt with a belt tension gauge as shown.

Periodic maintenance and adjustment

TIP

A belt tension gauge is available at a Yamaha dealer.

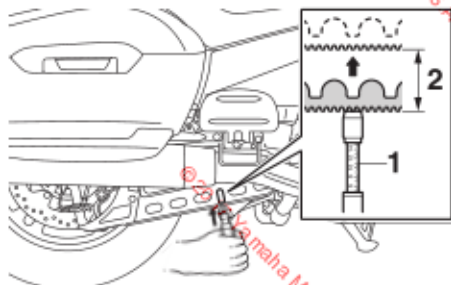

1. Belt tension gauge
2. Drive belt slack
3. Measure the drive belt slack
4. Calculate the drive belt slack by subtracting the measurement noted in step 2 from the measurement noted in step 3.

Drive belt slack:

4.0–6.0 mm (0.16–0.24 in)

5. If the drive belt slack is incorrect, have a Yamaha dealer adjust it.

Checking and lubricating the throttle grip

EAU82490

The operation of the throttle grip should be checked before each ride. In addition, the throttle grip housing should be lubricated by a Yamaha dealer at the intervals specified in the periodic maintenance chart.

Checking and lubricating the brake and shift pedals

EAU44276

The operation of the brake and shift pedals should be checked before each ride, and the pedal pivots should be lubricated if necessary.

Brake pedal

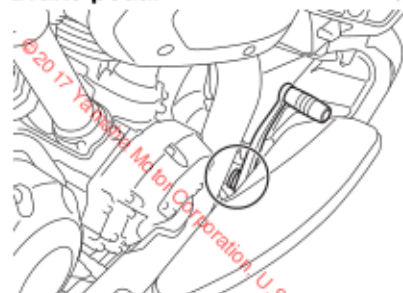

Shift pedal

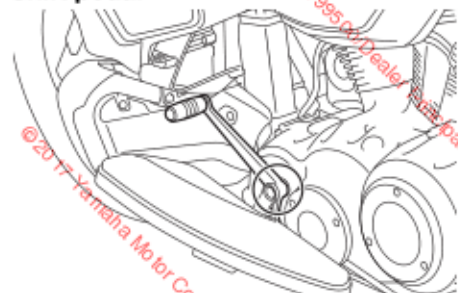

Periodic maintenance and adjustment

Recommended lubricant:
Lithium-soap-based grease

Checking and lubricating the brake and clutch levers

EAU43602

The operation of the brake and clutch levers should be checked before each ride, and the lever pivots should be lubricated if necessary.

Recommended lubricant:
Silicone grease

Brake lever

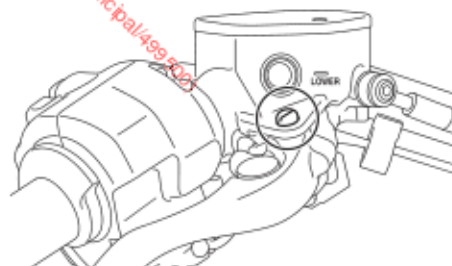

Clutch lever

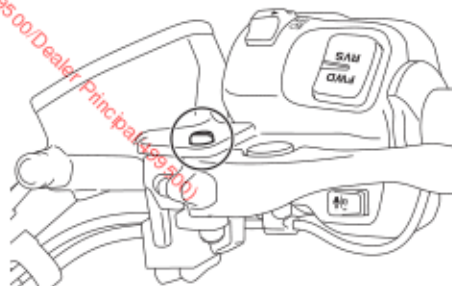

Periodic maintenance and adjustment

Checking and lubricating the sidestand

EAU23203

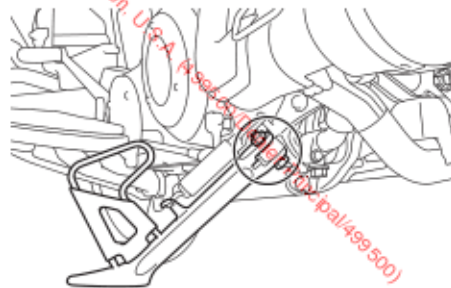

The operation of the sidestand should be checked before each ride, and the sidestand pivot and metal-to-metal contact surfaces should be lubricated if necessary.

WARNING

9 If the sidestand does not move up and down smoothly, have a Yamaha dealer check or repair it. Otherwise, the sidestand could contact the ground and distract the operator, resulting in a possible loss of control.

Recommended lubricant:
Lithium-soap-based grease

Lubricating the rear suspension

EAU23252

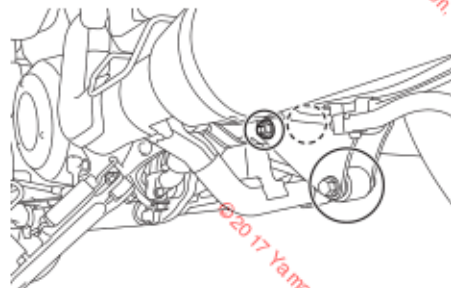

The pivoting points of the rear suspension must be lubricated by a Yamaha dealer at the intervals specified in the periodic maintenance and lubrication chart.

Recommended lubricant:
Lithium-soap-based grease

Lubricating the swingarm pivots

EAUM1853

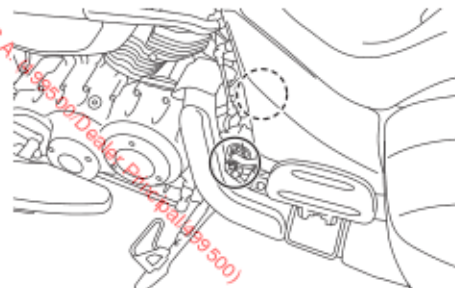

The swingarm pivots must be lubricated by a Yamaha dealer at the intervals specified in the periodic maintenance and lubrication chart.

Recommended lubricant:
Lithium-soap-based grease

EAU23273

Checking the front fork

The condition and operation of the front fork must be checked as follows at the intervals specified in the periodic maintenance and lubrication chart.

To check the condition

Check the inner tubes for scratches, damage and excessive oil leakage.

To check the operation

1. Place the vehicle on a level surface and hold it in an upright position. **WARNING! To avoid injury, securely support the vehicle so there is no danger of it falling over.** [EWA10752]
2. While applying the front brake, push down hard on the handlebars several times to check if the front fork compresses and rebounds smoothly.

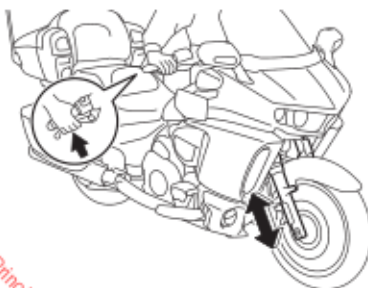

ECA1059

NOTICE

If any damage is found or the front fork does not operate smoothly, have a Yamaha dealer check or repair it.

EAU23285

Checking the steering

Worn or loose steering bearings may cause danger. Therefore, the operation of the steering must be checked as follows at the intervals specified in the periodic maintenance and lubrication chart.

1. Raise the front wheel off the ground. (See page 9-33.) **WARNING! To avoid injury, securely support the vehicle so there is no danger of it falling over.** [EWA10752]
2. Hold the lower ends of the front fork legs and try to move them forward and backward. If any free play can be felt, have a Yamaha dealer check or repair the steering.

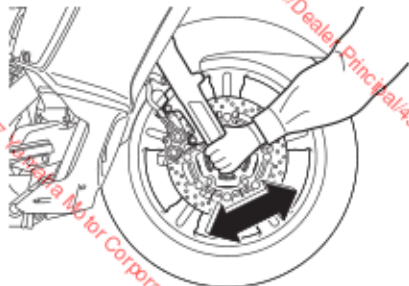

Periodic maintenance and adjustment

Checking the wheel bearings

EAU23292

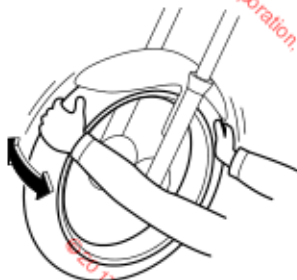

The front and rear wheel bearings must be checked at the intervals specified in the periodic maintenance and lubrication chart. If there is play in the wheel hub or if the wheel does not turn smoothly, have a Yamaha dealer check the wheel bearings.

Battery

EAU50292

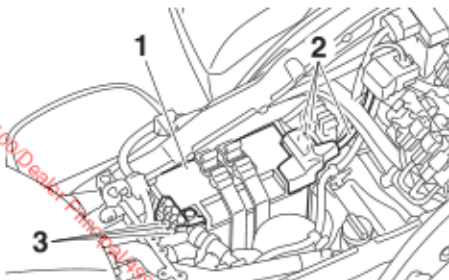

1. Battery
2. Positive battery lead (red)
3. Negative battery lead (black)

The battery is located under the seat. (See page 6-17.)

This model is equipped with a VRLA (Valve Regulated Lead Acid) battery. There is no need to check the electrolyte or to add distilled water. However, the battery lead connections need to be checked and, if necessary, tightened.

EWA10761

WARNING

- **Electrolyte is poisonous and dangerous since it contains sulfuric acid, which causes severe**

burns. Avoid any contact with skin, eyes or clothing and always shield your eyes when working near batteries. In case of contact, administer the following **FIRST AID**.

- **EXTERNAL:** Flush with plenty of water.
- **INTERNAL:** Drink large quantities of water or milk and immediately call a physician.
- **EYES:** Flush with water for 15 minutes and seek prompt medical attention.

- **Batteries produce explosive hydrogen gas. Therefore, keep sparks, flames, cigarettes, etc., away from the battery and provide sufficient ventilation when charging it in an enclosed space.**

- **KEEP THIS AND ALL BATTERIES OUT OF THE REACH OF CHILDREN.**

To charge the battery

Have a Yamaha dealer charge the battery as soon as possible if it seems to have discharged. Keep in mind that the

battery tends to discharge more quickly if the vehicle is equipped with optional electrical accessories.

ECA16522

NOTICE

To charge a VRLA (Valve Regulated Lead Acid) battery, a special (constant-voltage) battery charger is required. Using a conventional battery charger will damage the battery.

To store the battery

1. If the vehicle will not be used for more than one month, remove the battery, fully charge it, and then place it in a cool, dry place.

NOTICE: When removing the battery, be sure to turn the main switch off, then disconnect the negative lead before disconnecting the positive lead.

ECA16304

2. If the battery will be stored for more than two months, check it at least once a month and fully charge it if necessary.
3. Fully charge the battery before installation. **NOTICE: When installing the battery, be sure to turn the main switch off, then**

connect the positive lead before connecting the negative lead.

[ECA16842]

4. After installation, make sure that the battery leads are properly connected to the battery terminals.

ECA16531

NOTICE

Always keep the battery charged. Storing a discharged battery can cause permanent battery damage.

Replacing the fuses

Fuse boxes 1, 2, and 3 are located behind cowl A. (See page 9-9.)

To access the fuse boxes, remove the quick fastener, and then lift up the rubber cover.

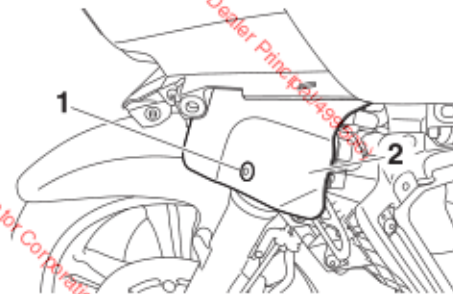

1. Quick fastener
2. Rubber cover

Periodic maintenance and adjustment

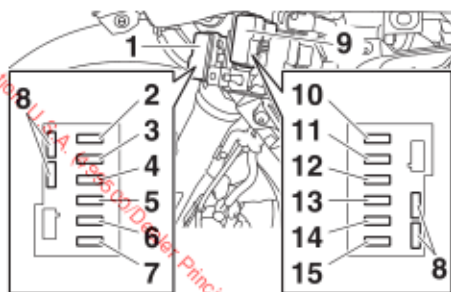

1. Fuse box 1
2. Electronic throttle valve fuse
3. Backup fuse 1 (for ECU)
4. Headlight fuse
5. Windshield motor fuse
6. Baggage fuse
7. Heater fuse 2
8. Spare fuse
9. Fuse box 2
10. Ignition fuse
11. Signaling system fuse
12. Windshield motor switch fuse
13. Backup fuse 2 (for meter)
14. Auxiliary DC jack fuse
15. Accessory main fuse

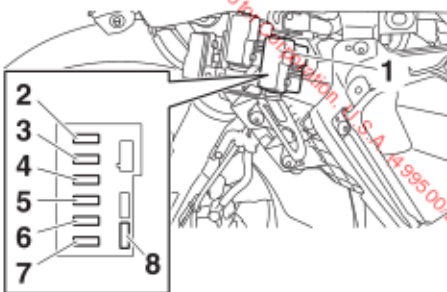

1. Fuse box 3
2. Ignition fuse 2
3. ABS control unit fuse
4. SURE-PARK fuse
5. Fuel injection system fuse
6. Brake light fuse
7. Cruise control fuse
8. Spare fuse

The main fuses, the audio system fuse, and fuse box 4 are located under the seat. (See page 6-17.)

TIP

To access the audio system fuse, remove the starter relay cover by pulling it upward.

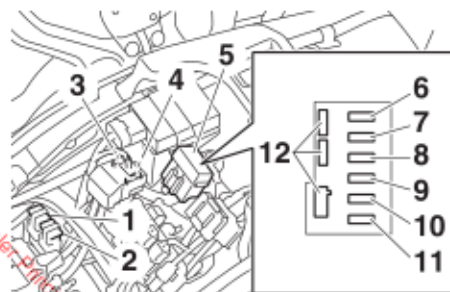

1. Main fuse
2. Main fuse 2
3. Audio system fuse
4. Audio system spare fuse
5. Fuse box 4
6. Heater (ACC) fuse
7. Heater fuse
8. Lighting fuse
9. Auxiliary DC connector fuse
10. ABS solenoid fuse
11. ABS motor fuse
12. Spare fuse

If a fuse is blown, replace it as follows.

1. Turn the main switch to "OFF" and turn off the electrical circuit in question.
2. Remove the blown fuse, and then install a new fuse of the specified amperage. **WARNING! Do not use a fuse of a higher amperage**

Periodic maintenance and adjustment

rating than recommended to avoid causing extensive damage to the electrical system and possibly a fire. [EWA15132]

Specified fuses:

Main fuse:
50.0 A
Main fuse 2:
50.0 A
Audio system fuse:
15.0 A

Specified fuses (fuse box 1):

Electronic throttle valve fuse:
7.5 A
Backup fuse:
10.0 A
Headlight fuse:
10.0 A
Windshield motor fuse:
10.0 A
Baggage fuse:
10.0 A
Heater fuse 2:
15.0 A

Specified fuses (fuse box 2):

Ignition fuse:
15.0 A
Signaling system fuse:
7.5 A
Windshield motor switch fuse:
7.5 A
Backup fuse 2:
7.5 A
Auxiliary DC jack fuse:
5.0 A
Accessory main fuse:
7.5 A

Specified fuses (fuse box 3):

Ignition fuse 2:
7.5 A
ABS control unit fuse:
7.5 A
SURE-PARK fuse:
7.5 A
Fuel injection system fuse:
10.0 A
Brake light fuse:
3.0 A
Cruise control fuse:
3.0 A

Specified fuses (fuse box 4):

Heater (ACC) fuse:
15.0 A
Heater fuse:
7.5 A
Lighting fuse:
7.5 A
Auxiliary DC connector fuse:
3.0 A
ABS solenoid fuse:
15.0 A
ABS motor fuse:
30.0 A

3. Turn the main switch to "ON" and turn on the electrical circuit in question to check if the device operates.
4. If the fuse immediately blows again, have a Yamaha dealer check the electrical system.

Periodic maintenance and adjustment

Vehicle lights

EAU72980

This model is equipped with full-LED lighting. There are no user replaceable bulbs.

If a light does not come on, check the fuses and then have a Yamaha dealer check the vehicle.

ECA16581

NOTICE

Do not affix any type of tinted film or stickers to the headlight lens.

Supporting the motorcycle

EAU24351

Since this model is not equipped with a centerstand, follow these precautions when removing the front and rear wheel or performing other maintenance requiring the motorcycle to stand upright. Check that the motorcycle is in a stable and level position before starting any maintenance. A strong wooden box can be placed under the engine for added stability.

a jack either under each side of the frame in front of the rear wheel or under each side of the swingarm.

To service the front wheel

1. Stabilize the rear of the motorcycle by using a motorcycle stand or, if an additional motorcycle stand is not available, by placing a jack under the frame in front of the rear wheel.
2. Raise the front wheel off the ground by using a motorcycle stand.

To service the rear wheel

Raise the rear wheel off the ground by using a motorcycle stand or, if a motorcycle stand is not available, by placing

Troubleshooting

EAU25853

Although Yamaha motorcycles receive a thorough inspection before shipment from the factory, trouble may occur during operation. Any problem in the fuel, compression, or ignition systems, for example, can cause poor starting and loss of power.

The following troubleshooting chart represents a quick and easy procedure for checking these vital systems yourself. However, should your motorcycle require any repair, take it to a Yamaha dealer, whose skilled technicians have the necessary tools, experience, and know-how to service the motorcycle properly.

Use only genuine Yamaha replacement parts. Imitation parts may look like Yamaha parts, but they are often inferior, have a shorter service life and can lead to expensive repair bills.

EWA15142

WARNING

When checking the fuel system, do not smoke, and make sure there are no open flames or sparks in the area, including pilot lights from water

heaters or furnaces. Gasoline or gasoline vapors can ignite or explode, causing severe injury or property damage.

Smart key system troubleshooting

EAU81720

Please check the following items.

When the smart key system does not work

- Is the smart key turned on? (See page 4-5.)
- Is the smart key battery discharged? (See page 4-6.)
- Is the smart key battery installed correctly? (See page 4-6.)
- Is the smart key being used in a location with strong radio waves or other electromagnetic noise? (See page 4-1.)
- Are you using the smart key that is registered to the vehicle?
- Is the vehicle battery discharged? When the vehicle battery is discharged, the smart key system will not operate. Please have the vehicle battery charged or replaced. (See page 9-29.)

If the smart key system does not work after checking the above items, have a Yamaha dealer check the smart key system.

TIP

See Emergency mode on page 9-36 for information on starting the engine without the smart key.

Periodic maintenance and adjustment

EAU42804

Troubleshooting chart

1. Fuel

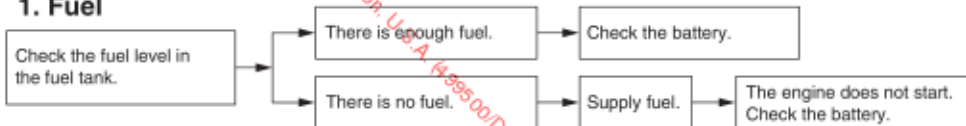

2. Battery

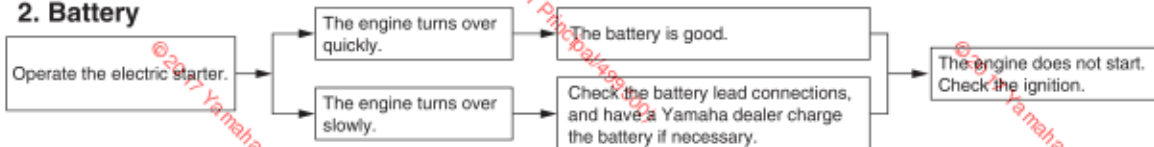

3. Ignition

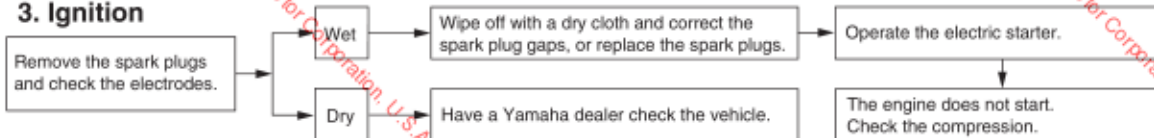

4. Compression



Periodic maintenance and adjustment

Emergency mode

When the smart key is lost, damaged, or its battery has discharged, the vehicle can still be turned on and the engine started. You will need a mechanical key and the smart key system identification number.



1. Identification number

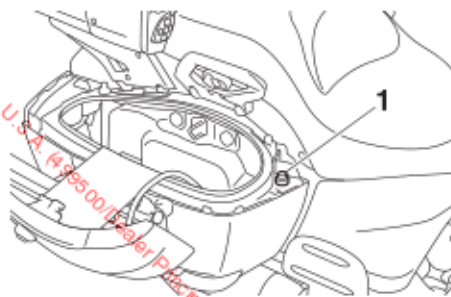
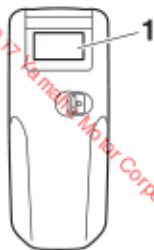

1. Emergency mode switch

4. The indicator light will come on for 3 seconds to indicate the transition to emergency mode.



1. Smart key system indicator light "⚡"

To operate the vehicle in emergency mode

1. Open the right saddlebag with a mechanical key.
2. Push the main switch knob once and release.
3. Within 10 seconds, push the emergency mode switch 3 times.

5. After the indicator light goes off, input the identification number as follows.

6. Inputting the identification number is done by holding the unlock switch "🔓" and counting the number of flashes of the indicator light.

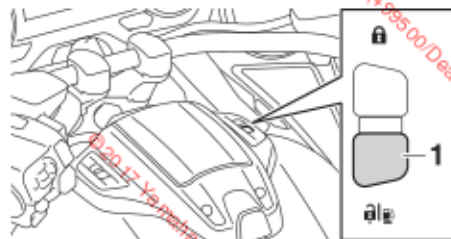

1. Unlock switch "🔓"

For example, if the identification number is 123456:

Push and hold the unlock switch.



The indicator light will start to flash.



Release the switch after the indicator light flashes once.



The first digit of the identification number has been input as "1".



Periodic maintenance and adjustment

Push and hold the unlock switch again.



Release the unlock switch after the indicator light flashes twice.



The second digit has been input as "2".



Repeat the above procedure until all digits of the identification number have been input. If correctly input, the indicator light will come on for 10 seconds.

7. While the indicator light is on, push the main switch knob once more to complete emergency mode access.

8. Within 5 seconds, turn the main switch to "ON". The engine can now be started, etc.

TIP

Emergency mode will be terminated (and the smart key system indicator light will flash quickly for 3 seconds) if any of the following occur. In this case, start over again from step 2.

- When there are no unlock switch operations for 10 seconds.
 - The identification number is not entered correctly.
-

Matte color caution

EAU37834

EAU57030

NOTICE

Some models are equipped with matte colored finished parts. Be sure to consult a Yamaha dealer for advice on what products to use before cleaning the vehicle. Using a brush, harsh chemical products or cleaning compounds when cleaning these parts will scratch or damage their surface. Wax also should not be applied to any matte colored finished parts.

ECA15193

Care

While the open design of a motorcycle reveals the attractiveness of the technology, it also makes it more vulnerable. Rust and corrosion can develop even if high-quality components are used. A rusty exhaust pipe may go unnoticed on a car, however, it detracts from the overall appearance of a motorcycle. Frequent and proper care does not only comply with the terms of the warranty, but it will also keep your motorcycle looking good, extend its life and optimize its performance.

Before cleaning

1. Cover the muffler outlets with plastic bags after the engine has cooled down.
 2. Make sure that all caps and covers as well as all electrical couplers and connectors, including the spark plug caps, are tightly installed.
- Remove extremely stubborn dirt, like oil burnt onto the crankcase, with a degreasing agent and a brush, but never apply such prod-

ucts onto seals, gaskets, the drive belt and wheel axles. Always rinse the dirt and degreaser off with water.

Cleaning

ECA10773

NOTICE

- Avoid using strong acidic wheel cleaners, especially on spoked wheels. If such products are used on hard-to-remove dirt, do not leave the cleaner on the affected area any longer than instructed. Also, thoroughly rinse the area off with water, immediately dry it, and then apply a corrosion protection spray.
- Improper cleaning can damage plastic parts (such as cowlings, panels, windshields, headlight lenses, meter lenses, etc.) and the mufflers. Use only a soft, clean cloth or sponge with water to clean plastic. However, if the plastic parts cannot be thoroughly cleaned with water, diluted mild detergent with water may be used. Be sure to rinse

Motorcycle care and storage

off any detergent residue using plenty of water, as it is harmful to plastic parts.

- Do not use any harsh chemical products on plastic parts. Be sure to avoid using cloths or sponges which have been in contact with strong or abrasive cleaning products, solvent or thinner, fuel (gasoline), rust removers or inhibitors, brake fluid, antifreeze or electrolyte.
- Do not use high-pressure washers or steam-jet cleaners since they cause water seepage and deterioration in the following areas: seals (of wheel and swing-arm bearings, fork and brakes), electric components (couplers, connectors, instruments, switches and lights), breather hoses and vents.
- For motorcycles equipped with a windshield: Do not use strong cleaners or hard sponges as they will cause dulling or scratching. Some cleaning compounds for plastic may leave scratches on the wind-

shield. Test the product on a small hidden part of the windshield to make sure that it does not leave any marks. If the windshield is scratched, use a quality plastic polishing compound after washing.

After normal use

Remove dirt with warm water, a mild detergent, and a soft, clean sponge and then rinse thoroughly with clean water. Use a toothbrush or bottlebrush for hard-to-reach areas. Stubborn dirt and insects will come off more easily if the area is covered with a wet cloth for a few minutes before cleaning.

After riding in the rain, near the sea or on salt-sprayed roads

Since sea salt or salt sprayed on roads during winter are extremely corrosive in combination with water, carry out the following steps after each ride in the rain, near the sea or on salt-sprayed roads.

TIP

Salt sprayed on roads in the winter may remain well into spring.

1. Clean the motorcycle with cold water and a mild detergent, after the engine has cooled down. **NOTICE: Do not use warm water since it increases the corrosive action of the salt.** [ECA10792]
2. After drying the motorcycle, apply a corrosion protection spray on all metal, including chrome- and nickel-plated, surfaces to prevent corrosion.

Windshield cleaning

Avoid using any alkaline or strong acid cleaner, gasoline, brake fluid, or any other solvent. Clean the windshield with a cloth or sponge dampened with a neutral detergent, and after cleaning, thoroughly wash it off with water. For additional cleaning, use Yamaha Windshield Cleaner or other quality cleaner. Some cleaning compounds for plastics may leave scratches on surfaces of the

Motorcycle care and storage

windshield. Before using them, make a test by polishing an area which does not affect your visibility.

After cleaning

1. Dry the motorcycle with a chamois or an absorbing cloth.
2. Use a chrome polish to shine chrome, aluminum and stainless-steel parts, including the exhaust system. (Even the thermally induced discoloring of stainless-steel exhaust systems can be removed through polishing.)
3. To prevent corrosion, it is recommended to apply a corrosion-protection spray on all metal, including chrome- and nickel-plated, surfaces.
4. Use spray oil as a universal cleaner to remove any remaining dirt.
5. Touch up minor paint damage caused by stones, etc.
6. Wax all painted and chrome-plated surfaces. Avoid combination cleaner waxes, many of which contain abrasives that may mar the paint or protective finish.

7. Let the motorcycle dry completely before storing or covering it.

EWA11132

WARNING

Contaminants on the brakes or tires can cause loss of control.

- **Make sure that there is no oil or wax on the brakes or tires.**
- **If necessary, clean the brake discs and brake linings with a regular brake disc cleaner or acetone, and wash the tires with warm water and a mild detergent. Before riding at higher speeds, test the motorcycle's braking performance and cornering behavior.**

ECA10951

NOTICE

- **Apply spray oil and wax sparingly and make sure to wipe off any excess.**
- **Never apply oil or wax to the drive belt.**
- **Never apply oil or wax to any rubber and plastic parts, but treat them with a suitable care product.**

- **Avoid using abrasive polishing compounds as they will wear away the paint.**

TIP

- Consult a Yamaha dealer for advice on what products to use.
- Washing, rainy weather or humid climates can cause the headlight lens to fog. Turning the headlight on for a short period of time will help remove the moisture from the lens.

Motorcycle care and storage

Storage

EAU4454

Short-term

Always store your motorcycle in a cool, dry place and, if necessary, protect it against dust with a porous cover. Be sure the engine and the exhaust system are cool before covering the motorcycle.

ECA10811

NOTICE

- Storing the motorcycle in a poorly ventilated room or covering it with a tarp, while it is still wet, will allow water and humidity to seep in and cause rust.
- To prevent corrosion, avoid damp cellars, stables (because of the presence of ammonia) and areas where strong chemicals are stored.

Long-term

Before storing your motorcycle for several months:

1. Follow all the instructions in the “Care” section of this chapter.

2. Fill up the fuel tank and add fuel stabilizer (if available) to prevent the fuel tank from rusting and the fuel from deteriorating.
3. Perform the following steps to protect the cylinders, piston rings, etc. from corrosion.
 - a. Remove the spark plug caps and spark plugs.
 - b. Pour a teaspoonful of engine oil into each spark plug bore.
 - c. Install the spark plug caps onto the spark plugs, and then place the spark plugs on the cylinder head so that the electrodes are grounded. (This will limit sparking during the next step.)
 - d. Turn the engine over several times with the starter. (This will coat the cylinder walls with oil.)**WARNING! To prevent damage or injury from sparking, make sure to ground the spark plug electrodes while turning the engine over.**
- e. Remove the spark plug caps from the spark plugs, and then install the spark plugs and the spark plug caps.
4. Lubricate all control cables and the pivoting points of all levers and pedals as well as of the side-stand/centerstand.
5. Check and, if necessary, correct the tire air pressure, and then lift the motorcycle so that both of its wheels are off the ground. Alternatively, turn the wheels a little every month in order to prevent the tires from becoming degraded in one spot.
6. Cover each muffler outlet with a plastic bag to prevent moisture from entering them.
7. Remove the battery and fully charge it. Store it in a cool, dry place and charge it once a month. Do not store the battery in an excessively cold or warm place [less than 0 °C (30°F) or more than 30 °C (90°F)]. For more information on storing the battery, see page 9-29.

[EWA10952]

TIP

Make any necessary repairs before storing the motorcycle.

Specifications

Dimensions:

- Overall length: 2700 mm (106.3 in)
- Overall width: 1015 mm (40.0 in)
- Overall height: 1410/1500 mm (55.5/59.1 in)
- Seat height: 695 mm (27.4 in)
- Wheelbase: 1710 mm (67.3 in)
- Ground clearance: 125 mm (4.92 in)
- Minimum turning radius: 3.5 m (11.48 ft)

Weight:

- Curb weight: 434 kg (957 lb) (Venture)
- 437 kg (963 lb) (Venture TC)

Engine:

- Combustion cycle: 4-stroke
- Cooling system: Air cooled
- Valve train: OHV
- Cylinder arrangement: V-type
- Number of cylinders: 2-cylinder
- Displacement: 1854 cm³
- Bore × stroke: 100.0 × 118.0 mm (3.94 × 4.65 in)

Compression ratio:

9.5 : 1

Starting system:

Electric starter

Lubrication system:

Dry sump

Engine oil:

Recommended brand:

YAMALUBE

SAE viscosity grades:

10W-40, 10W-50, 15W-40, 20W-40 or 20W-50

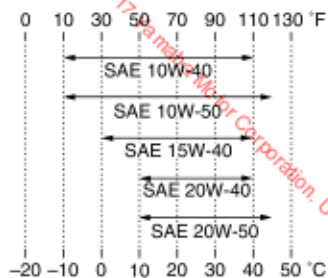

Recommended engine oil grade:

API service SG type or higher, JASO standard MA

Engine oil quantity:

- Oil change: 4.90 L (5.18 US qt, 4.31 Imp.qt)
- With oil filter removal: 5.30 L (5.60 US qt, 4.66 Imp.qt)

Air filter:

Air filter element:

Oil-coated paper element

Fuel:

Recommended fuel:

Premium unleaded gasoline (Gasohol [E10] acceptable)

Fuel tank capacity:

25 L (6.6 US gal, 5.5 Imp.gal)

Fuel reserve amount:

3.6 L (0.95 US gal, 0.79 Imp.gal)

Fuel injection:

Throttle body:

ID mark:

2DF1 00

Spark plug(s):

Manufacturer/model:

NGK/DPR7EA-9

Spark plug gap:

0.8–0.9 mm (0.031–0.035 in)

Clutch:

Clutch type:

Wet, multiple-disc

Drivetrain:

Primary reduction ratio:

1.412 (72/51)

Final drive:

Belt

Secondary reduction ratio:

2.333 (70/30)

Transmission type:

Constant mesh 6-speed

Gear ratio:

1st:

3.154 (41/13)

2nd:

2.105 (40/19)

- 3rd: 1.455 (32/22)
- 4th: 1.107 (31/28)
- 5th: 0.903 (28/31)
- 6th: 0.788 (26/33)

Chassis:

- Frame type: Double cradle
- Caster angle: 31.0 °
- Trail: 145 mm (5.7 in)

Front tire:

- Type: Tubeless
- Size: 130/70R18M/C63H
- Manufacturer/model: BRIDGESTONE/G853 RADIAL J (T/L)

Rear tire:

- Type: Tubeless
- Size: 200/55R16M/C 77H
- Manufacturer/model: BRIDGESTONE/G852 RADIAL J (T/L)

Loading:

- Maximum load: 185 kg (408 lb) (Venture TC)
- 188 kg (414 lb) (Venture)

(Total weight of rider, passenger, cargo and accessories)

Tire air pressure (measured on cold tires):

- Up to 90 kg (198 lb) load:
 - Front: 280 kPa (2.80 kgf/cm², 41 psi)
 - Rear: 280 kPa (2.80 kgf/cm², 41 psi)
- 90 kg (198 lb) load - maximum load:
 - Front: 280 kPa (2.80 kgf/cm², 41 psi)
 - Rear: 280 kPa (2.80 kgf/cm², 41 psi)

Front wheel:

- Wheel type: Cast wheel
- Rim size: 18M/CXMT3.50

Rear wheel:

- Wheel type: Cast wheel
- Rim size: 16M/CXMT6.00

Unified brake system:

- Operation: Brake lever and Brake pedal

Front brake:

- Type: Hydraulic dual disc brake
- Specified brake fluid: DOT 4

Rear brake:

- Type: Hydraulic single disc brake
- Specified brake fluid: DOT 4

Front suspension:

- Type: Telescopic fork
- Spring: Coil spring
- Shock absorber: Hydraulic damper
- Wheel travel: 130 mm (5.1 in)

Rear suspension:

- Type: Swingarm (link suspension)
- Spring: Air-pressurized coil spring
- Shock absorber: Gas-hydraulic damper
- Wheel travel: 110 mm (4.3 in)

Electrical system:

- System voltage: 12 V
- Ignition system: TCI
- Charging system: AC magneto

Battery:

- Model: YTX20L-BS

Specifications

Voltage, capacity:
12 V, 18.0 Ah (10 HR)

Bulb wattage:

Headlight:
LED
Brake/tail light:
LED
Front turn signal/position light:
LED
Rear turn signal light:
LED
Auxiliary light:
LED
Meter lighting:
LED
Meter lighting (fuel meter):
LED
Neutral indicator light:
LED
High beam indicator light:
LED
Oil pressure warning light:
LED
Turn signal indicator light:
LED
Fuel level warning light:
LED
Engine trouble warning light:
LED
ABS warning light:
LED
Cruise control "SET" indicator light:
LED

Cruise control "ON" indicator light:
LED
Smart key system indicator light:
LED
Traction control system indicator/warning light:
LED
Alarm indicator light:
LED
Fog lamp indicator light:
LED
SURE-PARK indicator light:
LED
Tire pressure warning light:
LED

Fuse(s):

Main fuse:
50.0 A
Main fuse 2:
50.0 A
Accessory main fuse:
7.5 A
SURE-PARK fuse:
7.5 A
Baggage fuse:
10.0 A
Heater fuse:
7.5 A
Heater fuse 2:
15.0 A
Heater (ACC) fuse:
15.0 A
Headlight fuse:
10.0 A

Brake light fuse:
3.0 A
Lighting fuse:
7.5 A
Signaling system fuse:
7.5 A
Ignition fuse:
15.0 A
Ignition fuse 2:
7.5 A
Fuel injection system fuse:
10.0 A
ABS control unit fuse:
7.5 A
ABS motor fuse:
30.0 A
ABS solenoid fuse:
15.0 A
Cruise control fuse:
3.0 A
Audio system fuse:
15.0 A
Auxiliary DC connector fuse:
3.0 A
Auxiliary DC jack fuse:
5.0 A
Backup fuse:
10.0 A
Backup fuse 2:
7.5 A
Windshield motor fuse:
10.0 A
Windshield motor switch fuse:
7.5 A

Electronic throttle valve fuse:

7.5 A

Consumer information

Identification numbers

EAU53682

Record the vehicle identification number, engine serial number, and the model label information in the spaces provided below. These identification numbers are needed when registering the vehicle with the authorities in your area and when ordering spare parts from a Yamaha dealer.

VEHICLE IDENTIFICATION NUMBER:

ENGINE SERIAL NUMBER:

MODEL LABEL INFORMATION:

Vehicle identification number

EAU26408



1. Vehicle identification number

The vehicle identification number is stamped into the steering head pipe. Record this number in the space provided.

TIP

The vehicle identification number is used to identify your motorcycle and may be used to register your motorcycle with the licensing authority in your area.

Engine serial number

EAU26442

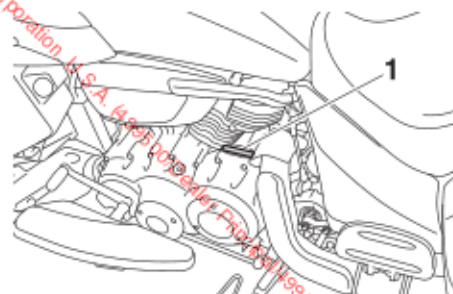

1. Engine serial number

The engine serial number is stamped into the crankcase.

Model label

EAU82221

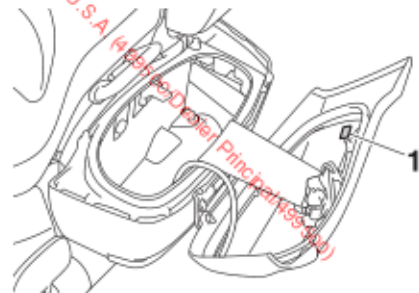

1. Model label

The model label is affixed to the underside of the left saddlebag lid. (See page 4-10.) Record the information on this label in the space provided. This information will be needed when ordering spare parts from a Yamaha dealer.

EAU48271

Vehicle Emission Control Information label

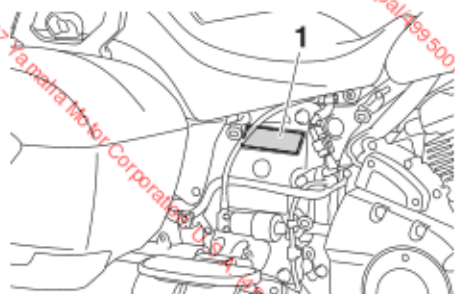

1. Vehicle Emission Control Information label

The Vehicle Emission Control Information label is affixed at the location in the illustration. This label shows specifications related to exhaust emissions as required by federal law, state law and Environment Canada.

Diagnostic connector

EAD09910

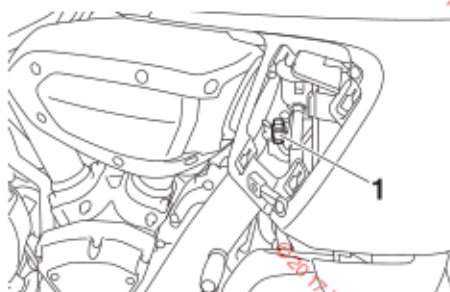

1. Diagnostic connector

The diagnostic connector is located as shown.

Vehicle data recording

This model's ECU stores certain vehicle data to assist in the diagnosis of malfunctions and for research and development purposes. This data will be uploaded only when a special Yamaha diagnostic tool is attached to the vehicle, such as when maintenance checks or service procedures are performed. Although the sensors and recorded data will vary by model, the main data points are:

- Vehicle status and engine performance data
- Fuel-injection and emission-related data

Yamaha will not disclose this data to a third party except:

- With the consent of the vehicle owner
- Where obligated by law
- For use by Yamaha in litigation
- For general Yamaha-conducted research purposes when the data is not related to an individual vehicle nor owner

Consumer information

EAU26553

Reporting safety defects

If you believe that your vehicle has a defect which could cause a crash or could cause injury or death, you should immediately inform the National Highway Traffic Safety Administration (NHTSA) in addition to notifying Yamaha Motor Corporation, U.S.A. If NHTSA receives similar complaints, it may open an investigation, and if it finds that a safety defect exists in a group of vehicles, it may order a recall and remedy campaign. However, NHTSA cannot become involved in individual problems between you, your dealer, or Yamaha Motor Corporation, U.S.A.

To contact NHTSA, you may call the Vehicle Safety Hotline toll-free at 1-888-327-4236 (TTY: 1-800-424-9153); go to <http://www.safercar.gov>; or write to: Administrator, NHTSA, 1200 New Jersey Avenue, SE, West Building, Washington, DC 20590. You can also obtain other information about motor vehicle safety from <http://www.safercar.gov>.

Motorcycle noise regulation

TAMPERING WITH NOISE CONTROL SYSTEM PROHIBITED:

Federal law prohibits the following acts or the causing thereof: (1) The removal or rendering inoperative by any person other than for purposes of maintenance, repair, or replacement of any device or element of design incorporated into any new vehicle for the purpose of noise control prior to its sale or delivery to the ultimate purchaser or while it is in use or (2) the use of the vehicle after such device or element of design has been removed or rendered inoperative by any person.

“AMONG THOSE ACTS PRESUMED TO CONSTITUTE TAMPERING ARE THE ACTS LISTED BELOW”.

These acts include tampering with the following systems; i.e., modification, removal, etc.

Exhaust system

- Muffler
- Exhaust pipe
- Silencer

Intake system

- Air cleaner case
- Air cleaner element
- Intake duct

Consumer information

EAU20833

Maintenance record

Copies of work orders and/or receipts for parts purchased and installed on your vehicle will be required to document that maintenance has been completed in accordance with the emissions warranty. The chart below is printed only as a reminder that maintenance work is required. It is not acceptable proof of maintenance work.

Maintenance interval	Date of service	Mileage	Servicing dealer name and address	Remarks
600 mi (1000 km) or 1 month				
4000 mi (7000 km) or 6 months				
8000 mi (13000 km) or 12 months				
12000 mi (19000 km) or 18 months				
16000 mi (25000 km) or 24 months				
20000 mi (31000 km) or 30 months				
24000 mi (37000 km) or 36 months				
28000 mi (43000 km) or 42 months				
32000 mi (49000 km) or 48 months				

Consumer information

Maintenance interval	Date of service	Mileage	Servicing dealer name and address	Remarks
36000 mi (55000 km) or 54 months				
40000 mi (61000 km) or 60 months				

Consumer information

YAMAHA MOTOR CORPORATION, U.S.A. 2015 AND LATER MODEL STREET & DUAL-PURPOSE MOTORCYCLE LIMITED WARRANTY

EAL/61802

Yamaha Motor Corporation, U.S.A. hereby warrants that each new Yamaha motorcycle purchased from an authorized Yamaha motorcycle dealer in the continental United States will be free from defects in material and workmanship for the period of time stated herein, subject to certain stated limitations.

THE PERIOD OF WARRANTY for Yamaha motorcycles originally equipped with headlight, stoplight, and turn signals shall be one (1) year from the date of purchase, with no mileage limitation, except for the battery, which is warranted for thirty (30) days from the date of purchase.

MODELS EXCLUDED FROM WARRANTY include those used for non-Yamaha authorized renting, leasing, or other commercial purposes.

DURING THE PERIOD OF WARRANTY any authorized Yamaha motorcycle dealer will, free of charge, repair or replace, at Yamaha's option, any part adjudged defective by Yamaha due to faulty workmanship or material from the factory. Parts used in warranty repairs will be warranted for the balance of the product's warranty period. All parts replaced under warranty become the property of Yamaha Motor Corporation, U.S.A.

GENERAL EXCLUSIONS from this warranty shall include any failures caused by:

- Competition or racing use.
- Installation of parts or accessories that are not qualitatively equivalent to genuine Yamaha parts.
- Abnormal strain, neglect, or abuse.
- Lack of proper maintenance and off-season storage as described in the Owner's Manual.
- Accident or collision damage.
- Modification to original parts.
- Damage due to improper transportation.

SPECIFIC EXCLUSIONS from this warranty shall include parts replaced due to normal wear or routine maintenance.

THE CUSTOMER'S RESPONSIBILITY under this warranty shall be to:

- Operate and maintain the motorcycle as specified in the appropriate Owner's Manual, and
- Give notice to an authorized Yamaha motorcycle dealer of any and all apparent defects within ten (10) days after discovery, and make the machine available at that time for inspection and repairs at such dealer's place of business.

WARRANTY TRANSFER: To transfer the warranty from the original purchaser to any subsequent purchaser, it is imperative that the machine be inspected and registered for warranty by an authorized Yamaha motorcycle dealer. In order for this warranty to remain in effect, this inspection and registration must take place within ten (10) days after transfer. A reasonable dealer-imposed fee may be charged for the inspection.

EMISSIONS CONTROL SYSTEM WARRANTY

Yamaha Motor Corporation, U.S.A. also warrants to the ultimate purchaser and each subsequent purchaser of each Yamaha motorcycle covered by this warranty with a displacement of 50cc or greater, that the vehicle is designed, built, and equipped so as to conform at the time of sale with all U.S. emissions standards applicable at the time of manufacture and that it is free from defects in materials and workmanship which would cause it not to meet these standards within the periods listed immediately below. Failures other than those resulting from defects in material or workmanship which arise solely as a result of owner abuse and/or lack of proper maintenance are not covered by this warranty.

ENGINE DISPLACEMENT	PERIOD
50cc to 169cc	12,000 km (7,465 miles) or five years, whichever occurs first
170cc to 279cc	18,000 km (11,185 miles) or five years, whichever occurs first
280cc or over	30,000 km (18,641 miles) or five years, whichever occurs first

YAMAHA MOTOR CORPORATION, U.S.A. MAKES NO OTHER WARRANTY OF ANY KIND, EXPRESSED OR IMPLIED, ALL IMPLIED WARRANTIES OF MERCHANTABILITY AND FITNESS FOR A PARTICULAR PURPOSE WHICH EXCEED THE OBLIGATIONS AND TIME LIMITS STATED IN THIS WARRANTY ARE HEREBY DISCLAIMED BY YAMAHA MOTOR CORPORATION, U.S.A. AND EXCLUDED FROM THIS WARRANTY.

SOME STATES DO NOT ALLOW LIMITATIONS ON HOW LONG AN IMPLIED WARRANTY LASTS, SO THE ABOVE LIMITATIONS MAY NOT APPLY TO YOU. ALSO EXCLUDED FROM THIS WARRANTY ARE ANY INCIDENTAL OR CONSEQUENTIAL DAMAGES INCLUDING LOSS OF USE. SOME STATES DO NOT ALLOW THE EXCLUSION OR LIMITATION OF INCIDENTAL OR CONSEQUENTIAL DAMAGES, SO THE ABOVE EXCLUSION MAY NOT APPLY TO YOU.

THIS WARRANTY GIVES YOU SPECIFIC LEGAL RIGHTS, AND YOU MAY ALSO HAVE OTHER RIGHTS WHICH VARY FROM STATE TO STATE.

YAMAHA MOTOR CORPORATION, U.S.A.
P.O. Box 6555
Cypress, California 90630
Customer Relations: 1-800-962-7926

WARRANTY QUESTIONS AND ANSWERS

- Q. What costs are my responsibility during the warranty period?
- A. The customer's responsibility includes all costs of normal maintenance services, non-warranty repairs, accident and collision damages, and oil, oil filters, air filters, spark plugs, and brake shoes.
- Q. What are some examples of "abnormal" strain, neglect, or abuse?
- A. These terms are general and overlap each other in areas. Specific examples include: Running the machine out of oil, sustained high rpm, full-throttle, operating the machine with a broken or damaged part which causes another part to fail, damage or failure due to improper or careless transportation and/or tie-down. If you have any specific questions on operation or maintenance, please contact your dealer for advice.
- Q. Does the warranty cover incidental costs such as towing or transportation due to a failure?
- A. No. The warranty is limited to repair of the machine itself.
- Q. May I perform any or all of the recommended maintenance shown in the Owner's Manual instead of having the dealer do them?
- A. Yes, if you are a qualified mechanic and follow the procedures specified in the Owner's and Service Manual. We do recommend, however, that items requiring special tools or equipment be done by a Yamaha motorcycle dealer.
- Q. Will the warranty be void or cancelled if I do not operate or maintain my new motorcycle exactly as specified in the Owner's Manual?
- A. No. The warranty on a new motorcycle cannot be "voided" or "cancelled." **However, if a particular failure is caused by operation or maintenance other than as described in the Owner's Manual, that failure may not be covered under warranty.**
- Q. What responsibility does my dealer have under this warranty?
- A. Each Yamaha motorcycle dealer is expected to:
1. Completely set up every new machine before sale.
 2. Explain the operation, maintenance, and warranty requirements to your satisfaction at the time of sale, and upon your request at any later date.
 3. Each Yamaha motorcycle dealer is held responsible for his setup, service and warranty repair work.
- Q. Is the warranty transferable to second owners?
- A. Yes. The remainder of the existing warranty can be transferred upon request. The unit has to be inspected and re-registered by an authorized Yamaha motorcycle dealer for the policy to remain effective.

CUSTOMER SERVICE

If your machine requires warranty service, you must take it to any authorized Yamaha motorcycle dealer within the continental United States. Be sure to bring your warranty registration card or other valid proof of the original date of purchase. If a question or problem arises regarding the warranty, first contact the owner of the dealership. Since all warranty matters are handled at the dealer level, this person is in the best position to help you. If you are still not satisfied and require additional assistance, please write to:

YAMAHA MOTOR CORPORATION, U.S.A.
CUSTOMER RELATIONS DEPARTMENT
P.O. Box 6555
Cypress, California 90630

When contacting Yamaha Motor Corporation, U.S.A., don't forget to include any important information such as names, addresses, model, VIN (vehicle identification number), dates, and receipts.

CHANGE OF ADDRESS

The federal government requires each manufacturer of a motor vehicle to maintain a complete, up-to-date list of all first purchasers against the possibility of a safety-related defect and recall. This list is compiled from the purchase registrations sent to Yamaha Motor Corporation, U.S.A. by the selling dealer at the time of your purchase.

If you should move after you have purchased your new motorcycle, please advise us of your new address by sending a postcard listing your motorcycle model name, VIN number, dealer number (or dealer's name) as it is shown on your warranty card, your name and new mailing address. Mail to:

YAMAHA MOTOR CORPORATION, U.S.A.
1270 Chastain Road
Kennesaw, GA 30144
Attention: Warranty Department

This will ensure that Yamaha Motor Corporation, U.S.A. has an up-to-date registration record in accordance with federal law.

YAMAHA EXTENDED SERVICE (Y.E.S.)

Keep your Yamaha protected even after your limited warranty expires with genuine Yamaha Extended Service (Y.E.S.).

- Y.E.S. is designed and administered by Yamaha Motor Corporation to provide maximum owner satisfaction. It provides uninterrupted factory-backed coverage for extra peace of mind.
- Y.E.S. is flexible. You choose the plan that's right for you: 12 months, 24 months, 36 months or, on certain models, even 48 months beyond your warranty period.
- Y.E.S. is designed and administered by the same Yamaha people who handle your warranty – and it shows in the comprehensive coverage benefits. There are no mileage limitations. Coverage isn't limited to "moving parts" or the "drivetrain" like many other plans. And Y.E.S. covers manufacturing defects just like the warranty. See the sample contract at your Yamaha dealer to see how comforting uninterrupted factory-backed protection can be.
- You don't have to pay anything for covered repairs. There's no deductible to pay, and repairs aren't "pro-rated." You don't have any "out-of-pocket" expenses for covered repairs.

- In addition, Travel and Recreation Interruption Protection (TRIP) is included at no extra cost. TRIP gives you up to \$250 reimbursement per occurrence for any reasonable expenses you incur because your Yamaha needs covered service: replacement vehicle rental, emergency towing, phone calls, even food and lodging when you are away from home. This superb coverage goes into effect when you purchase Y.E.S., so it applies to any warranty repairs as well as covered repairs during your entire Y.E.S. plan period.
- Y.E.S. coverage is honored at any authorized Yamaha dealer nationwide.
- Y.E.S. coverage is transferable to a new owner if you sell or trade-in. That can make your Yamaha much more valuable!

This excellent Y.E.S. plan coverage is only available to Yamaha owners like you, and only while your Yamaha is still within the Yamaha Limited Warranty period. So visit your authorized Yamaha dealer to get all the facts. They can show you how easy it is to protect your investment with Yamaha Extended Service.

Consumer information

We urge you to act now. You'll get the excellent benefits of TRIP coverage right away, and you'll rest easy knowing you'll have strong factory-backed protection even after your Yamaha Limited Warranty expires.

A special note:

If visiting your dealer isn't convenient, contact Yamaha with your VIN number and we'll be happy to help you get the Y.E.S. coverage you need.

Yamaha Service Marketing
P.O. Box 6555
Cypress, CA 90630
1-(866)-YES-EXTD (1-866-937-3983)



YAMAHA EXTENDED SERVICE

- A**
- ABS warning light6-5
 - Adjustable footrests6-25
 - Adjustable wind deflector6-25
 - Air filter element, replacing9-16
 - Alarm indicator light (Venture TC)6-5
 - Alarm system (Venture TC)5-6
 - Audio controls (passenger)6-28
 - Auxiliary DC jack6-27
- B**
- Battery9-29
 - Brake and clutch fluids, changing9-24
 - Brake and clutch levers, checking and lubricating9-26
 - Brake and shift pedals, checking and lubricating9-25
 - Brake fluid level, checking9-23
 - Brake lever6-11
 - Brake lever free play, checking9-21
 - Brake light switches9-21
 - Brake pedal6-11
 - Brake system6-12
- C**
- Canister9-12
 - Care10-1
 - Catalytic converters6-11
 - Clutch lever6-10, 9-20
 - Compartment access4-10
 - Cowling and panels, removing and installing9-9
 - Cruise control indicator lights6-4
 - Cruise control switches6-2
 - Cruise control system5-3
- D**
- Data recording, vehicle12-2
 - Diagnostic connector12-2
 - Dimmer/Pass switch6-1
 - D-mode (drive mode)6-9
 - Drive belt slack9-24
 - Drive mode switch6-2
- E**
- Emergency mode9-36
 - Engine break-in8-4
 - Engine idling speed, checking9-17
 - Engine oil and oil filter cartridge9-13
 - Engine serial number12-1
 - Engine stop switch6-2
 - Engine trouble warning light6-4
- F**
- Fog lamp indicator light6-3
 - Fog lamp switch (Venture TC)6-2
 - Front and rear brake pads, checking ... 9-22
 - Front fork, checking9-28
 - Fuel6-15
 - Fuel level warning light6-4
 - Fuel tank cap6-14
 - Fuel tank overflow hose6-16
 - Fuses, replacing9-30
- H**
- Handlebar switches6-1
 - Hazard switch6-2
 - Headset jacks6-28
 - Helmet holder6-19
 - High beam indicator light6-3
 - Horn switch6-1
- I**
- Identification numbers12-1
- J**
- Ignition circuit cut-off system6-29
 - Indicator lights and warning lights6-3
 - Infotainment system5-2
- K**
- Key, handling of smart and mechanical keys4-3
- L**
- Labels, location1-1
 - Leg air vents6-25
- M**
- Main switch4-7
 - Maintenance and lubrication, periodic ... 9-5
 - Maintenance, emission control system9-3
 - Maintenance record12-5
 - Matte color, caution10-1
 - Model label12-1
- N**
- Navigation controls6-2
 - Neutral indicator light6-3
 - Noise regulation12-4
- O**
- Oil pressure warning light6-4
 - Operating range of the smart key4-3
- P**
- Parking8-4
 - Part 15 of FCC Rules4-2
 - Part locations3-1
- R**
- Rear suspension, lubricating9-27
 - Rear view mirrors6-22
- S**
- Saddlebags and tour trunk6-23
 - Safety defects, reporting12-3

Safety information	2-1	Tool kit	9-2
Seat	6-17	TPMS	9-20
Seat heater switch (passenger)	6-19	Traction control system	6-13
Shifting	8-2	Traction control system indicator light... ..	6-5
Shift pedal	6-10	Troubleshooting	9-34
Shock absorber assembly, adjusting	6-26	Troubleshooting chart	9-35
Sidestand	6-29	Turn signal indicator lights	6-3
Sidestand, checking and lubricating	9-27	Turn signal switch	6-1
Smart key	4-5	V	
Smart key battery, replacing	4-6	Valve clearance	9-17
Smart key system	4-1	Vehicle Emission Control Information label	12-2
Smart key system indicator light	6-5	Vehicle identification number	12-1
Smart key system, troubleshooting	9-34	Vehicle lights	9-33
Spark plugs, checking	9-11	Volume switch	6-2
Special features	5-1	W	
Specifications	11-1	Warranty, extended	12-9
Speedometer and tachometer	6-6	Warranty, limited	12-7
Starting the engine	8-1	Wheel bearings, checking	9-29
Start switch	6-2	Wheels	9-19
Steering, checking	9-28	Windshield	6-22
Storage	10-4		
Storage compartments	6-20		
Supporting the motorcycle	9-33		
SURE-PARK	5-1		
SURE-PARK indicator light	6-3		
SURE-PARK switch	6-2		
Swingarm pivots, lubricating	9-27		
T			
Talk button (passenger)	6-28		
Talk button (rider)	6-2		
Throttle grip, checking and lubricating	9-25		
Tire pressure warning light	6-6		
Tires	9-17		

©2017 Yamaha Motor Corporation, U.S.A. (4-995-00/Dealer Principal/499500)

©2017 Yamaha Motor Corporation, U.S.A. (4-995-00/Dealer Principal/499500)

©2017 Yamaha Motor Corporation, U.S.A. (4-995-00/Dealer Principal/499500)

©2017 Yamaha Motor Corporation, U.S.A. (4-995-00/Dealer Principal/499500)

©2017 Yamaha Motor Corporation, U.S.A. (4-995-00/Dealer Principal/499500)

©2017 Yamaha Motor Corporation, U.S.A. (4-995-00/Dealer Principal/499500)

©2017 Yamaha Motor Corporation, U.S.A. (4-995-00/Dealer Principal/499500)

©2017 Yamaha Motor Corporation, U.S.A. (4-995-00/Dealer Principal/499500)

©2017 Yamaha Motor Corporation, U.S.A. (4-995-00/Dealer Principal/499500)

For your best ownership experience, think **Genuine Yamaha!**

Genuine Yamaha Parts – Genuine Yamaha replacement parts are the exact same parts as the ones originally equipped on your vehicle, providing you with the performance and durability you have come to expect. Why settle for aftermarket parts that may not provide full confidence and satisfaction?

Genuine Yamaha Accessories – Yamaha only offers accessories that meet our high standards for quality and performance. Buy with confidence, knowing your Genuine Yamaha Accessories will fit right and perform right – right out of the box.

Yamalube – Take care of your Yamaha with legendary Yamalube oils, lubricants, and care products. They're formulated and approved by the toughest judges we know: the Yamaha engineering teams that know your Yamaha from the inside out.

Genuine Yamaha Service Manuals – Get the same factory manual for your vehicle that the technicians at your authorized Yamaha dealer use. Service manuals are available through your Yamaha dealer or you can order them directly through yamahapubs.com (for US consumers only).

Genuine Yamaha products are available only from your Yamaha dealer.

Find out more at:

For US consumers, please visit yamaha-motor.com

For Canadian consumers, please visit yamaha-motor.ca

©2017 Yamaha Motor Corporation, U.S.A. (499500/Dealer Principal/499500)



PRINTED ON RECYCLED PAPER

PRINTED IN JAPAN
2017.05-0.7×1 CR
(E)